



# TLSZ Guardmaster Guard Locking Switch

Catalog Numbers 440G-TZS21UPRH, 440G-TZS21UPLH,  
440G-TZS21UTRH, 440G-TZS21UTLH



**Allen-Bradley**

by ROCKWELL AUTOMATION

Guardmaster®

User Manual

Original Instructions

# Important User Information

Read this document and the documents listed in the additional resources section about installation, configuration, and operation of this equipment before you install, configure, operate, or maintain this product. Users are required to familiarize themselves with installation and wiring instructions in addition to requirements of all applicable codes, laws, and standards.

Activities including installation, adjustments, putting into service, use, assembly, disassembly, and maintenance are required to be carried out by suitably trained personnel in accordance with applicable code of practice.

If this equipment is used in a manner not specified by the manufacturer, the protection provided by the equipment may be impaired.

In no event will Rockwell Automation, Inc. be responsible or liable for indirect or consequential damages resulting from the use or application of this equipment.

The examples and diagrams in this manual are included solely for illustrative purposes. Because of the many variables and requirements associated with any particular installation, Rockwell Automation, Inc. cannot assume responsibility or liability for actual use based on the examples and diagrams.

No patent liability is assumed by Rockwell Automation, Inc. with respect to use of information, circuits, equipment, or software described in this manual.

Reproduction of the contents of this manual, in whole or in part, without written permission of Rockwell Automation, Inc., is prohibited.

Throughout this manual, when necessary, we use notes to make you aware of safety considerations.



**WARNING:** Identifies information about practices or circumstances that can cause an explosion in a hazardous environment, which may lead to personal injury or death, property damage, or economic loss.



**ATTENTION:** Identifies information about practices or circumstances that can lead to personal injury or death, property damage, or economic loss. Attentions help you identify a hazard, avoid a hazard, and recognize the consequence.

**IMPORTANT**

Identifies information that is critical for successful application and understanding of the product.

These labels may also be on or inside the equipment to provide specific precautions.



**SHOCK HAZARD:** Labels may be on or inside the equipment, for example, a drive or motor, to alert people that dangerous voltage may be present.



**BURN HAZARD:** Labels may be on or inside the equipment, for example, a drive or motor, to alert people that surfaces may reach dangerous temperatures.



**ARC FLASH HAZARD:** Labels may be on or inside the equipment, for example, a motor control center, to alert people to potential Arc Flash. Arc Flash will cause severe injury or death. Wear proper Personal Protective Equipment (PPE). Follow ALL Regulatory requirements for safe work practices and for Personal Protective Equipment (PPE).

The following icon may appear in the text of this document.



Identifies information that is useful and can help to make a process easier to do or easier to understand.

	About This Publication . . . . .	5
	Who Should Use This Manual . . . . .	5
	Summary of Changes . . . . .	5
	Additional Resources . . . . .	5
	Terminology . . . . .	6
	<b>Chapter 1</b>	
<b>Product Overview</b>	Guardmaster TLSZ Guard Locking Switch Overview . . . . .	7
	Catalog Number Explanation . . . . .	7
	Packaging Contents . . . . .	8
	<b>Chapter 2</b>	
<b>Installation</b>	General Considerations . . . . .	9
	Actuator/Target Mounting . . . . .	9
	Allowable Approach Directions . . . . .	9
	Minimum Operating Radius . . . . .	10
	Manual Release . . . . .	10
	Manual Override Cover . . . . .	11
	Pair Proximity . . . . .	11
	Guide Repositioning . . . . .	11
	Steel Locking Bolts . . . . .	12
	Actuator Clearance . . . . .	12
	Approximate Dimensions . . . . .	13
	<b>Chapter 3</b>	
<b>Wiring</b>	Connections . . . . .	15
	OSSD Inputs . . . . .	15
	OSSD Outputs . . . . .	15
	Auxiliary Output . . . . .	16
	Lock Command . . . . .	16
	<b>Chapter 4</b>	
<b>Commissioning</b>	Preparation . . . . .	17
	First Time Power-up . . . . .	17
	Learn First Target . . . . .	18
	Learn Additional Targets . . . . .	18
	Commissioning Errors . . . . .	19
	Power-up Self-check . . . . .	19
	<b>Chapter 5</b>	
<b>Functional Testing</b>	Testing Procedure . . . . .	21
	<b>Chapter 6</b>	
<b>Application and Wiring Examples</b>	Wiring to GLP Relay . . . . .	23
	Circuit Status as Shown . . . . .	24

	Wiring to GLT Relay . . . . .	24
	Circuit Status as Shown . . . . .	25
	Wiring to DI and EMD Relay . . . . .	26
	Circuit Status as Shown . . . . .	26
	Wiring to DG Relay . . . . .	27
	Wiring to CR30 Software Configurable Safety Relay . . . . .	28
	Wiring to 1734 POINT Guard I/O . . . . .	30
	Wiring to 1732 ArmorBlock . . . . .	34
	 <b>Chapter 7</b>	
<b>Diagnostics and Troubleshooting</b>	Tools Needed . . . . .	39
	Required Tools . . . . .	39
	Optional Tools . . . . .	39
	Flowchart . . . . .	40
	Step 1 – Status Indicator Off . . . . .	40
	Step 2 – Status Indicator Flashing Red at 4 Hz . . . . .	41
	Wrong Target . . . . .	41
	Missing Target . . . . .	41
	Target Not Mounted Correctly . . . . .	42
	Pair Proximity . . . . .	42
	Mechanical Pressure on Safety Gate . . . . .	42
	Long Wiring . . . . .	43
	Voltage Supply Dips . . . . .	44
	Rapid Locking . . . . .	44
	Step 3 – Status Indicator Flashes Red at 1 Hz . . . . .	45
	Capacitive Loading . . . . .	45
	Step 4 – Status Indicator Flashes Green at 1 Hz . . . . .	46
	Corrective Action . . . . .	46
	Step 5 – Flashing Red and Green . . . . .	46
	Step 6 – Indicator Steady Red . . . . .	46
	Step 7 – Other Considerations . . . . .	46
Distribution Block . . . . .	46	
GSR Relays on Power-up . . . . .	47	
	 <b>Appendix A</b>	
<b>Specifications</b>	Safety Ratings . . . . .	49
	Operating Characteristics . . . . .	49
	Environmental . . . . .	50
	General . . . . .	50
	Declaration of Conformity . . . . .	50
	CE Conformity . . . . .	51
UKCA Conformity . . . . .	51	
	 <b>Index . . . . .</b>	<b>53</b>

## About This Publication

This manual is a reference guide for the Guardmaster® TLSZ guard locking switch. This manual:

- Explains how to install and wire your TLSZ guard locking switch.
- Provides an overview of the Guardmaster TLSZ guard locking switch.

## Who Should Use This Manual

Use this manual to design, install, program, or troubleshoot systems that use the TLSZ Guardmaster guard locking safety switches.

You are required to have a basic understanding of electrical circuitry and familiarity with safety-related control systems. If you do not, obtain the proper training before using this product.

## Summary of Changes

This publication contains the following new or updated information. This list includes substantive updates only and is not intended to reflect all changes.

Topic	Page
Updated <a href="#">Figure 1</a>	8
Updated <a href="#">Figure 12</a>	13
Updated <a href="#">Table 5</a> and <a href="#">Table 6</a>	18
Updated Pair Proximity	42
Updated Solenoid duty cycle and Response time (off)	49
Updated Risk time, max	50

## Additional Resources

These documents contain additional information concerning related products from Rockwell Automation.

Resource	Description
Guardmaster Configurable Safety Relay Wiring Diagrams, publication <a href="#">440C-WD001</a>	Provides example wiring diagrams for the CR30 software configuration safety relay.
Industrial Automation Wiring and Grounding Guidelines, publication <a href="#">1770-4.1</a>	Provides general guidelines for installing a Rockwell Automation® industrial system.
Functional Safety Data Sheet, publication <a href="#">SAFETY-SR001</a>	Provides functional safety data and details for Rockwell Automation products.
Industrial Automation Glossary, publication <a href="#">AG-7.1</a>	Glossary of industrial automation terms and abbreviations
Product Certifications website, <a href="http://rok.auto/certifications">rok.auto/certifications</a> .	Provides declarations of conformity, certificates, and other certification details.

You can view or download publications at [rok.auto/literature](http://rok.auto/literature).

## Terminology

The [Industrial Automation Glossary](#) contains terms and abbreviations that are used by Rockwell Automation to describe industrial automation systems. [Table 1](#) lists specific terms and abbreviations that are used in this manual.

**Table 1 - Terminology**

<b>Term</b>	<b>Description</b>
NC	No connection
N.C. (Normally Closed)	An electrical contact whose normal state (for example, no pressure or electrical potential applied) is in the closed position.
N.O. (Normally Open)	An electrical contact whose normal state (such as no pressure or electrical potential applied) is in the open position.
PLC	A programmable logic controller or a programmable automation controller.
PTL (Power to Lock)	Apply 24V to the lock command to lock the switch. This command applies to the TLSZL guard locking switch.
PTR (Power to Release)	Apply 24V to the lock command to unlock the switch. This command applies to the TLSZR guard locking switch.
Reaction Time	Describes the time between the true state of the input to the on state of the output.
Response Time	Describes the time between the trigger of the input to the off state of the output. Throughout this manual, the safety outputs are described as turning off immediately (turning off within the response time).
RFID	Radio frequency identification.
OSSD (Output Signal Switching Device)	Typically a pair of solid-state signals pulled up to the DC source supply. The signals are tested for short circuits to the DC power supply, short circuits to the DC common, and short circuits between the two signals.
Standard coding	Same as low coding as defined in EN ISO 14119:2013
TLSZL	TLSZ Power to Lock guard locking switch
TLSZR	TLSZ Power to Release guard locking switch
Unique coding	Same as high coding as defined in EN ISO 14119:2013

## Product Overview

### Guardmaster TLSZ Guard Locking Switch Overview

This Guardmaster® TLSZ guard locking switch functions by locking its actuator, which prohibits the opening of a guard.

The TLSZ guard locking switch uses radio frequency identification, RFID, coding to detect the appropriate target.

This version of the Guardmaster TLSZ guard locking switch features OSSD outputs. These outputs are enabled only when the actuator is locked and the RF target is sensed.

This device is intended to be part of the safety-related control system of a machine. Perform a risk assessment before installation to determine whether the specifications of this device are suitable for all operational and environmental characteristics of the machine. See [Specifications on page 49](#) for certification information and ratings.

Use nonremovable screws, bolts, or nuts to mount the switch and actuators. Do not over torque the mounting hardware.

TLSZ guard locking switches are classified according to ISO 14119 as Type 4 switching devices. The RFID targets are classified as having a high level of coding.

Take measures to minimize the need to defeat and to manage the use and availability of spare RFID targets.

### Catalog Number Explanation

440  
a
G - T  
b      c
Z  
d
S21  
e
U  
f
P  
g
R  
h
H  
i

a	
Code	Description
440	Safeguards the product

b	
Code	Description
G	Guard locking switch

c	
Code	Description
T	Titan locking switch

d	
Lock Type	
Code	Description
Z	PLe rated, cascadable safety signals

e	
Connection Type	
Code	Description
S21	Solid-state outputs, 2 safety (OSSD), 1 aux

f	
Special Features	
Code	Description
U	Unique coded RFID target

g	
Lock Type	
Code	Description
P	Aux signal shows lock status
T	Aux signal shows door status

h	
Connection Type	
Code	Description
R	Power to Release
L	Power to Lock

i	
Special Features	
Code	Description
H	8-pin M12 QD connector



**ATTENTION:** Guard locking switches that use the Power to Lock principle can only be used after a risk assessment shows that the Power to Release principle is inappropriate for the application. If a power supply loss occurs with Power to Lock switches, the switches immediately unlock and you can access the hazards.

## Packaging Contents

Figure 1 shows the contents in the shipping package. The contents include:

- Switch
- Actuator
- RFID target
- T20 security Torx bit
- Two steel bolts and nuts
- Plug
- Installation instructions (not shown)

Figure 1 - Package Contents



## Installation

### General Considerations

The TLSZ guard locking switch is designed for use on guards that are engineered to be rigid and without sag. The TLSZ guard locking switch uses radio frequency identification (RFID) coding to detect the appropriate target.

### Actuator/Target Mounting

[Figure 2](#) shows the correct and incorrect ways to mount the target with the actuator.

The TLSZ guard locking switch must only be used with the fully flexible actuator. The replacement part number for the actuator is catalog number 440G-A27143.

**Figure 2 - Target/Actuator Mounting**

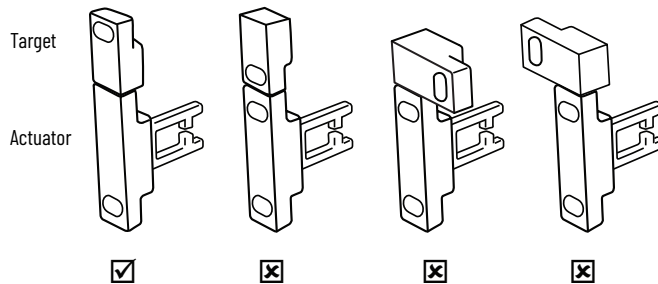

### Allowable Approach Directions

The actuator and target must be always mounted as close coupled and can approach the switch in any of the three entry slot positions that are shown in [Figure 3](#). Approach from the underside is not allowed, as the distance from the target to the internal RF sensor is too far for proper operation.

**Figure 3 - Allowable Approach Direction**

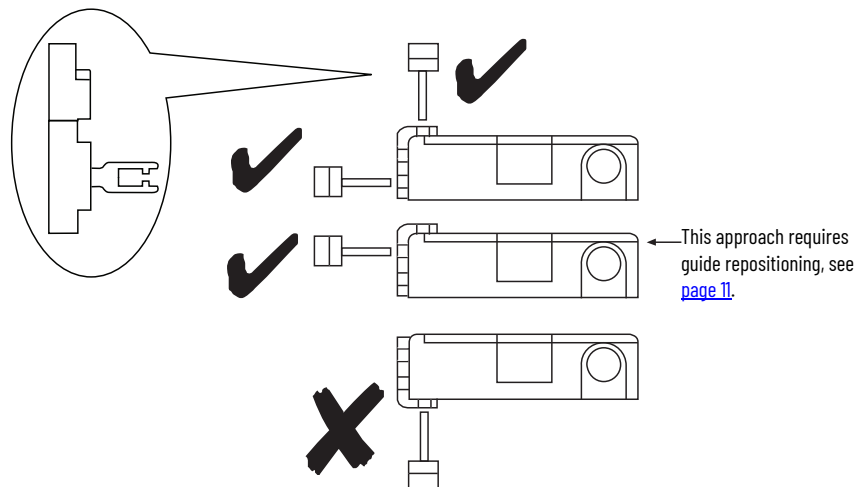

## Minimum Operating Radius

[Figure 4](#) shows the minimum operating distances along the length and perpendicular when applied to hinged doors.

**Figure 4 - Minimum Operating Distance [mm (in.)]**

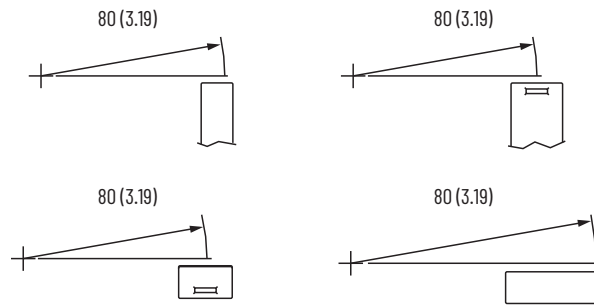

[Figure 5](#) shows the location of the two 1.5 mm (0.06 in.) set screws that can be adjusted to preset the actuator to an optimal angle, if needed.

**Figure 5 - Actuator Set Screw [mm (in.)]**

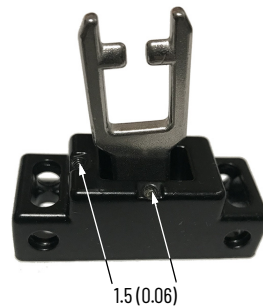

## Manual Release

The manual release feature only applies to the TLSZR (Power to Release) switch. In some cases, you must manually release the locked actuator.

[Figure 6](#) shows the two locations from which the actuator can be manually released.

1. Remove the T20 Torx screw.
2. Insert a small screwdriver or rod in the hole.
3. Release the actuator.

If power is applied to the switch when the actuator is released, the OSSD safety outputs turn off and the switch goes to a faulted state with the status indicator flashing red at 4 Hz. Power then must be cycled to the switch to return it to an operational state.

**Figure 6 - Manual Release**

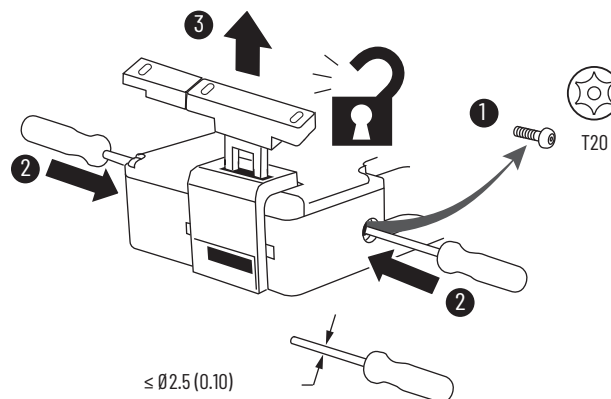

## Manual Override Cover

[Figure 7](#) shows an optional cover that is available only for the TLSZR (Power to Release) switch. This cover has a lever that allows you to unlock the actuator manually at any time. Rotate the lever 90° to unlock the actuator.

If power is applied to the switch when the actuator is released, the OSSD safety outputs turn off, and the switch goes to a faulted state with the status indicator flashing red at 4 Hz. Power is then cycled to the switch to return it to an operational state.

**Figure 7 - Manual Override Cover**

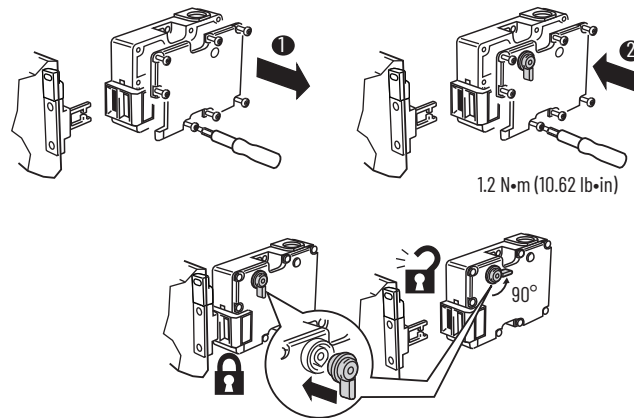

## Pair Proximity

If a pair of TLSZ guard locking switches are mounted too close to each other, the two RF fields could interact causing crosstalk. Cross-talk results in nuisance faults.

Maintain a minimum distance between guard locking switches for correct operation.

- Series E and earlier: 200 mm (8 in.)
- Series F and later: 75mm (3 in.)

The restriction also applies if a TLSZ guard locking switch is mounted close to the 440G-LZ guard locking and the 440N-Z SensaGuard™ switches.

## Guide Repositioning

The actuator guide can be repositioned to facilitate alignment of the actuator. In steps 8...11 ([Figure 8](#)), rotate the metal guide to allow the switch body to be fastened flush to the mounting surface.

**Figure 8 - Guide Repositioning**

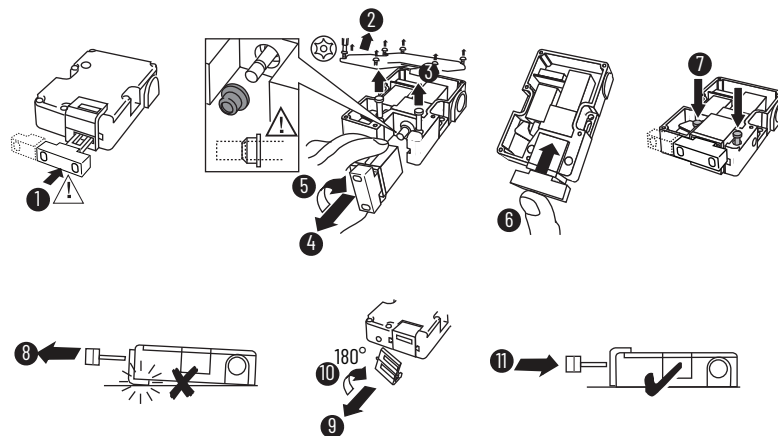

## Steel Locking Bolts

The TLSZ guard locking switch is assembled in the factory with plastic pins that secure the actuator guide. The plastic pins are rated for a holding force of 1500 N (337 lb). The plastic pins must be replaced with the steel bolts to achieve a holding force of 2000 N (585 lb). [Figure 9](#) shows how to remove the cover to replace the blue plastic pins with steel bolts.

**Figure 9 - Steel Bolt Installation**

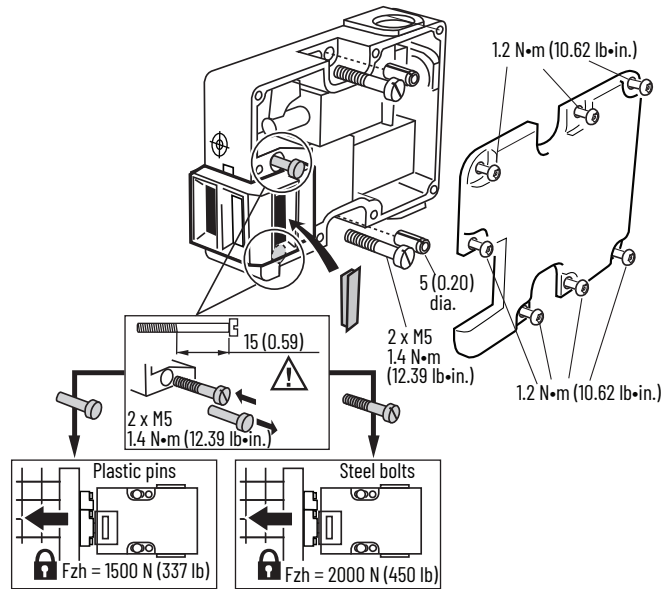

## Actuator Clearance

[Figure 10](#) shows the clearance requirements for the TLSZ guard locking switch. The switch must not be used as a guard stop. You must provide a mechanical stop at least 1 mm (0.04 in.) away from the actuator guide. The actuator must be inserted within 4 mm (0.16 in.) or less from the actuator guide to be sure it locks.

**Figure 10 - Clearance and Insertion Distance [mm (in.)]**

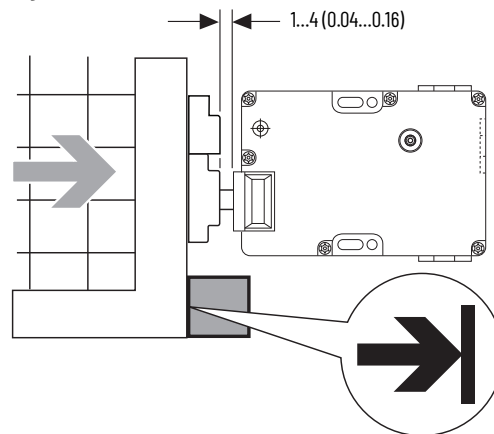

As shown in [Figure 11 on page 13](#), the TLSZ guard locking switch has two slotted holes to facilitate installation. The slots allow up to 8 mm (0.31 in.) of movement of the switch body to achieve the proper clearance with the actuator.

1. Use the slotted holes for initial installation.
2. After alignment with the actuator, secure the switch body in place by adding mounting hardware in the circular holes.

- To attain the maximum holding force, replace the plastic pins with steel screws inside the cover.

**Figure 11 - Mounting Slots for Alignment [ mm (in.) ]**

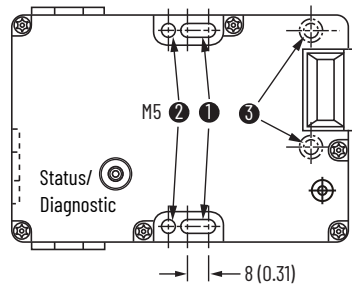

## Approximate Dimensions

Figure 12 shows the approximate dimensions for the switch, target, and actuator.

**Figure 12 - Approximate Dimensions [ mm (in.) ]**

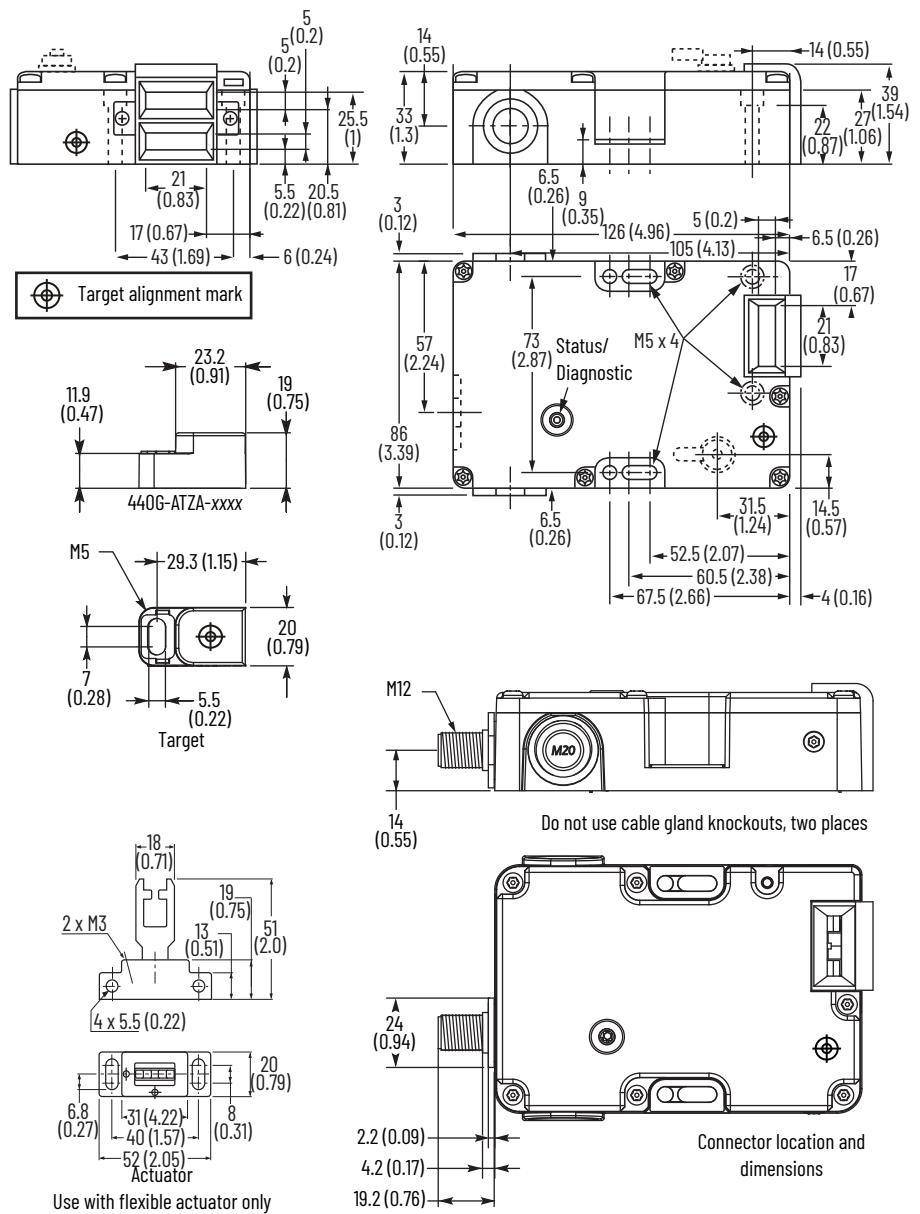
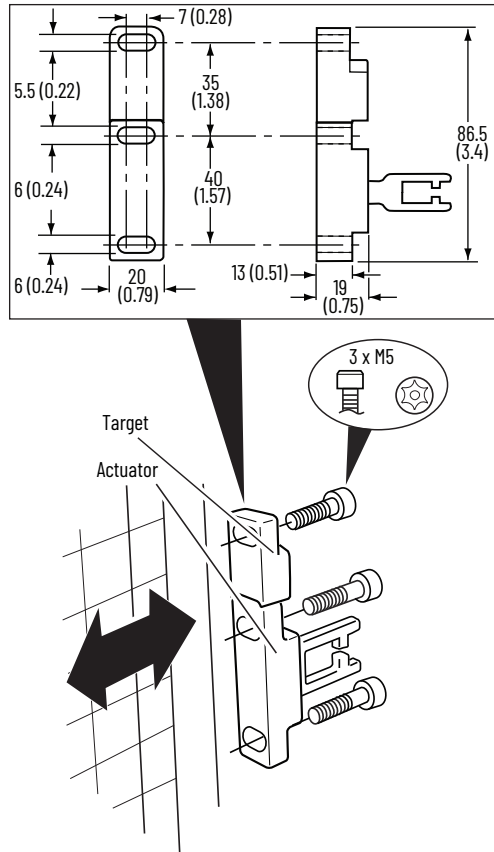

Figure 13 shows the dimensions for mounting the target that is next to the actuator.

Figure 13 - Actuator/Target Mounting Dimensions [mm (in.)]



## Wiring

### Connections

The TLSZ guard locking switch is only available with an 8-pin DC Micro M12 quick-disconnect connector. [Table 2](#) shows the pin assignments and their functions and typical mating cordsets. Other cordsets are available at <https://www.rockwellautomation.com/en-us/products/hardware/allen-bradley/connection-devices/cables-and-cordsets/dc-micro--m12-/dc-micro-cordsets-and-patchcords.html>.

**Table 2 - 8-pin Micro Quick Disconnect Pin Assignments**

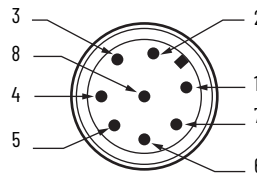

Pin	Color	Function
1	White	Aux
2	Brown	24V DC supply
3	Green	Lock command
4	Yellow	Safety B+ input
5	Gray	Safety A output (OSSD A)
6	Pink	Safety B output (OSSD B)
7	Blue	Ground (0V)
8	Red	Safety A+ input

Typical mating cordsets: 889D-F8NB-x (Red, PVC), 889D-F8AB-x (Black, PVC)  
 x = 2 [2 m (6.56 ft)], 5 [5 m (16.4 ft)], 10 [10 m (32.8 ft)], 15 [15 m (49.2 ft)] 20 [20 m (65.62 ft)] or 30 [30 m (98.4 ft)]  
 for standard cable lengths. The TLSZ guard locking switch is tested to operate with up to 120 m (393.7 ft) of the mating cables.

### OSSD Inputs

The OSSD inputs are Safety A+ and Safety B+. These inputs can be pure 24V DC, or they can contain test pulses. The OSSD inputs allow the TLSZ guard locking switches to be connected in-series while maintaining a high level of safety performance.

### OSSD Outputs

The OSSD outputs are Safety A and Safety B. These outputs are 24V signals that contain test pulses. The test pulses are used to detect short circuits to 24V, to 0V and cross faults (from Safety A to Safety B). This description of the test pulses is provided for informational purposes; you cannot modify them.

[Figure 14 on page 16](#) shows the safety output test pulses when connected to a 1K resistive load for hardware (HW) revisions A and B, and for firmware (FW) revisions A through C. The pulses are 25  $\mu$ s wide and repeat every 20 ms. The exact shape of the pulses depends on the nature of the load. The capacitive and resistive effects of the load are determined with the combination of cabling, cable routing, and connected devices.

Figure 14 - Output Test Pulses

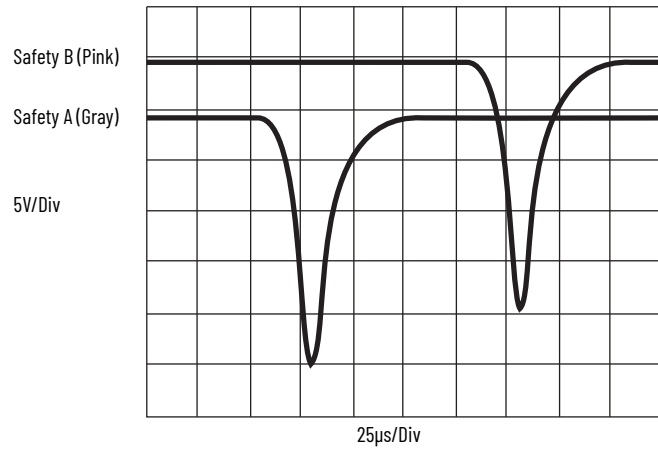

## Auxiliary Output

Table 3 shows the auxiliary output functions. The auxiliary output is a 24V DC logic signal, whose function is dependent on the catalog number selected. The auxiliary signal responds independently of the OSSD safety outputs. The auxiliary output is not a safety-rated signal and must only be used to indicate the status of the switch.

Table 3 - Auxiliary Output Function

Cat. No.	Function	Value
440G-TZS2IUPRH 440G-TZS2IUPLH	Lock status	24V when the actuator is unlocked 0V when the actuator is locked
440G-TZS2IUTRH 440G-TZS2IUTLH	Actuator status	24V when the actuator is inserted (gate closed) 0V when the actuator is removed (gate open)

## Lock Command

Table 4 shows the lock command function. The lock command is a 24V logic signal, with a current of less than 5 mA. The function of the logic signal is dependent on the catalog number. The 24V power supply connection provides the power to operate the locking solenoid.

Table 4 - Lock Command Function

Cat. No.	Switch Type	Function
440G-TZS2IUPRH 440G-TZS2IUTRH	Power to Release	24V unlocks the actuator 0V locks the actuator
440G-TZS2IUPLH 440G-TZS2IUTLH	Power to Lock	24V locks the actuator 0V unlocks the actuator

## Commissioning

Before use, the guard locking switch must first learn a new RFID target. This step is not done at the factory.

The guard locking switch can learn up to eight targets consecutively. Use this process if there is a potential for the target to become damaged, inoperable, or lost. When a new target is learned, the guard locking switch no longer recognizes the old target.

### Preparation

Wire the guard locking switch with at minimum the functionality shown in [Figure 15](#).

- Power – Connect the brown wire to +24V.
- Gnd – Connect the blue wire to 0V.
- Lock – Leave the green wire open when learning the first target. Connect the green wire to 24V to teach a TLSZR guard locking switch subsequent targets. The TLSZL guard locking switch ignores the Lock command during learning.
- Safety A+ and Safety B+ – Connect red and yellow wires to 24V during commissioning. If 24V is not applied to the A+ and B+ inputs, then the indicator flashes green after commissioning if the guard locking switch is locked.
- Safety A and Safety B – Optional, no connection required for commissioning.
- Aux – Optional, no connection required for commissioning.

Figure 15 - Commissioning Wiring

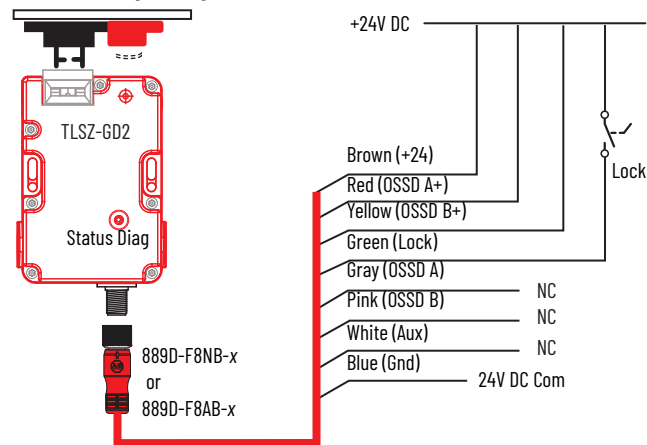

### First Time Power-up

Turn on the 24V DC power without the actuator and target.

The Status/Diagnostic indicator flashes green three times, pauses 2 seconds, and then flashes green eight times. Eight is the number of times a new target can be learned. The guard locking switch continuously repeats the two-second pause followed by the eight flash sequence.

## Learn First Target

[Table 5](#) shows the events that take place when the first target is learned. The lock command is ignored until after the guard locking switch learns its first target, therefore, the lock command can be 24V or 0V during the first-time learning sequence.

**Table 5 - First Target Learning Events**

Step	Event	Indicator Color	Blink Rate	Duration
1	Apply power to guard locking switch	Red	Solid	–
2	Present actuator/target	Red	Solid	–
3	Detect target	Red	Solid	2...25 s
4	Verifying target (not for Series F guard locking switches)	Green/red	1 Hz	15 s
5	Report commissioning error (see <a href="#">Table 7 on page 19</a> ) or continue	–	–	–
6	Programming switch	Green/red	4 Hz	15 s
7	Finalizing	Red	Solid	2 s
8	Number of learns remaining	Green	# of learns	15 s
9	Learn completed PTR PTL	Green Red	Solid	Continuous

## Learn Additional Targets

[Table 6](#) shows the steps that take place when teaching the guard locking switch to recognize an additional target. For PTR switches, the lock command must connect to +24V to learn additional targets. The PTL switch ignores the lock command during learning.

**Table 6 - Additional Target Learning Steps**

Step	Event	Indicator Color	Blink Rate	Duration
1	Apply power to guard locking switch PTR: Apply 24V to lock command PTL: Ignores lock command	Red	Solid	–
2	Present new actuator/target	Red	Solid	–
3	Detect target	Red	Solid	3...25 s
4	PTR: Solenoid automatically locks PTL: No action	Red	Solid	0.5 s
5	Verifying target (not for Series F guard locking switches)	Green/red	1 Hz	15 s
6	Report commissioning error (see <a href="#">Table 7 on page 19</a> ) or continue	–	–	–
7	Programming switch	Green/red	4 Hz	15 s
8	Finalizing	Red	Solid	2 s
9	Number of learns remaining	Green	# of learns	15 s
10	PTR: Solenoid unlocks then locks PTL: no action	–	–	0.5 s
11	Learn completed PTR PTL	Red Red	4 Hz Solid	Continuous
12	PTR: Cycle power PTL: Ready for use	–	–	–

## Commissioning Errors

During commissioning, the guard locking switch performs certain checks. If an error is detected, the Status/Diagnostic indicator reports the error. [Table 7](#) lists the commissioning error codes. The error code is generated after the guard locking switch verifies the target. If an error code is generated, the guard locking switch must be power cycled before further learning is started.

**Table 7 - Commissioning Error Codes**

Indicator Flashes (4 Hz)	Code
Red-Red-Red-Green-Green	Target already learned
Red-Red-Red-Green-Green-Green	Bad RFID Target that is removed while programming PTL
Red-Red-Red-Green-Green-Green-Green	Exceeded learning eight targets

## Power-up Self-check

Upon power-up, the TLSZ guard locking switch performs an internal self-check, which takes approximately 3 seconds. Whether the actuator/target is inserted and the lock command is present; the indicator remains red or turns green after the self-check. [Table 8](#) shows the indicator sequence during self-check with the actuator/target inserted. The self-check sequence occurs only once.

**Table 8 - Self-check Indicator Sequence**

Model	Lock Signal	Indicator Sequence	OSSD Outputs
TLSZR	OFF	Green-Green-Green-Red-Green	ON
	ON	Green-Green-Green-Red	OFF
TLSZL	OFF	Green-Green-Green-Red	OFF
	ON	Green-Green-Green-Red-Green	ON

**Notes:**

## Functional Testing

A manual functional electric test must be done:

- After installation
- After any maintenance or change of component
- If the guard is used infrequently
  - Less than once per month for SIL 3/PLe
  - Less than once per year for SIL 2/PLd

### Testing Procedure



**ATTENTION:** During the functional test, confirm that there are no persons in the danger area and that the machine startup causes no hazard.

1. Confirm that the guard door is open.
2. Connect the 24V DC power to pin 2 and ground (0V) to pin 7. The guard locking switch conducts a self-testing routine at the end of which the diagnostic indicator shows steady red.
3. Test to confirm that the machine cannot start.
4. Confirm the lock command at pin 3 is set to 0V for PTR and 24V for PTL types.
5. Test again to confirm that the machine cannot start.
6. Close the guard door and then confirm that the guard is mechanically locked and the diagnostic indicator shows steady green.
7. Test to confirm that the machine can now start.
8. Change the lock command at pin 3. Set it to 24V for PTR and 0V for PTL types.
9. Confirm the machine stops, the guard door is mechanically unlocked, and the machine cannot restart.

**Notes:**

## Application and Wiring Examples

The following application and wiring examples are intended to show how the TLSZ products can be applied. Variations to the following examples can be required to meet your specific requirements.

### Wiring to GLP Relay

The GLP safety relay is designed to operate with PTR guard locking switches. To use a PTR guard locking switch, you must use an interposing relay on the lock command at GLP terminal 51. In the example shown in [Figure 16](#), the GLP safety relay allows the gate to unlock when the motor is running at a Safely-limited Speed.

Figure 16 - GLP and TLSZR Schematic

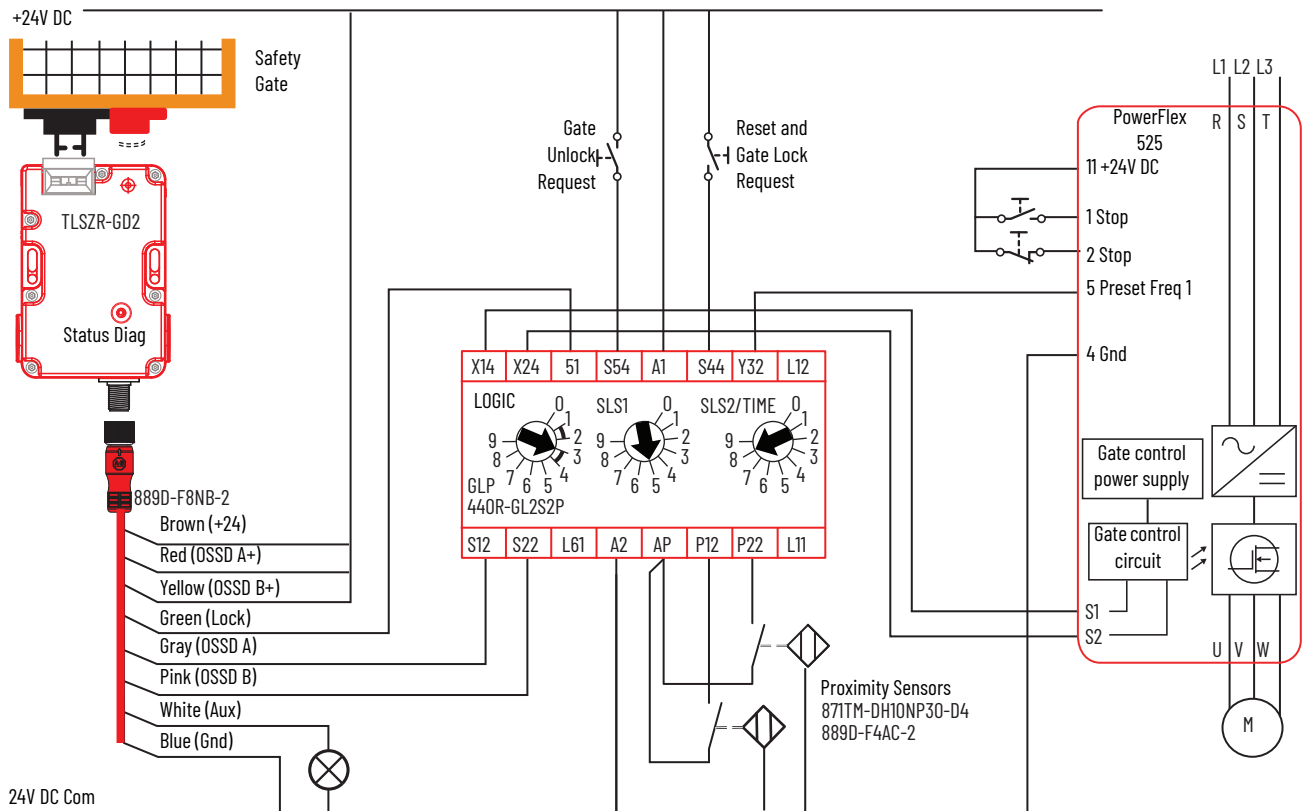

## Circuit Status as Shown

The gate is open and unlocked. The motor is off. The GLP is ready for reset. The GLP safety relay has a Logic setting of 3: (Safely-limited Speed with Logic IN OFF), a Safely-limited Speed (SLS1) setting of 5 (5 Hz) and a maximum (SLS2) speed setting of 8 (2000 Hz). The safety outputs (X14 and X24), the single wire safety output (L11), and the auxiliary output (Y32) are off.

---

**IMPORTANT** Start the GLP logic configuration from 0 to configure X14 and X24 for use as safety outputs.

---

### *Starting*

Close the gate and press Reset to lock the gate and turn on the GLP safety outputs. Press Start to turn on the motor.

### *Safely-limited Speed*

A normal production stop is performed by pressing Stop. Access through the safety gate is initiated by pressing Gate Unlock Request. The Y32 output of the GLP safety relay turns on and commands that the PowerFlex® drive to bring the motor to a safe slow speed (Preset Freq 1). When the proximity sensors detect the speed has dropped below the Safely-limited Speed (5 Hz), the gate becomes unlocked. The operator can enter the machine cell, as the motor continues to run at the safe slow speed. After you leave the cell and close the gate, press Reset to lock the gate and return the machine to production speeds.

The circuit meets the safety requirements up to Category 3, Performance Level d in accordance with ISO 13849-1 and SIL CL 2 in accordance with IEC 62061.

## Wiring to GLT Relay

The GLT safety relay is designed to operate with PTR guard locking switches. To use a PTL guard locking switch, you must use an interposing relay on the lock command at terminal 51 of the GLP safety relay.

In this example shown in [Figure 17 on page 25](#), the GLT safety relay sends an immediate command to the drive to turn off. After 8 seconds, the GLT safety relay turns off its safety outputs and unlocks the gate. The risk assessment must determine the adequate time delay for the machine to achieve a safe state before unlocking the gate.

Figure 17 - GLT and TLSZR Schematic

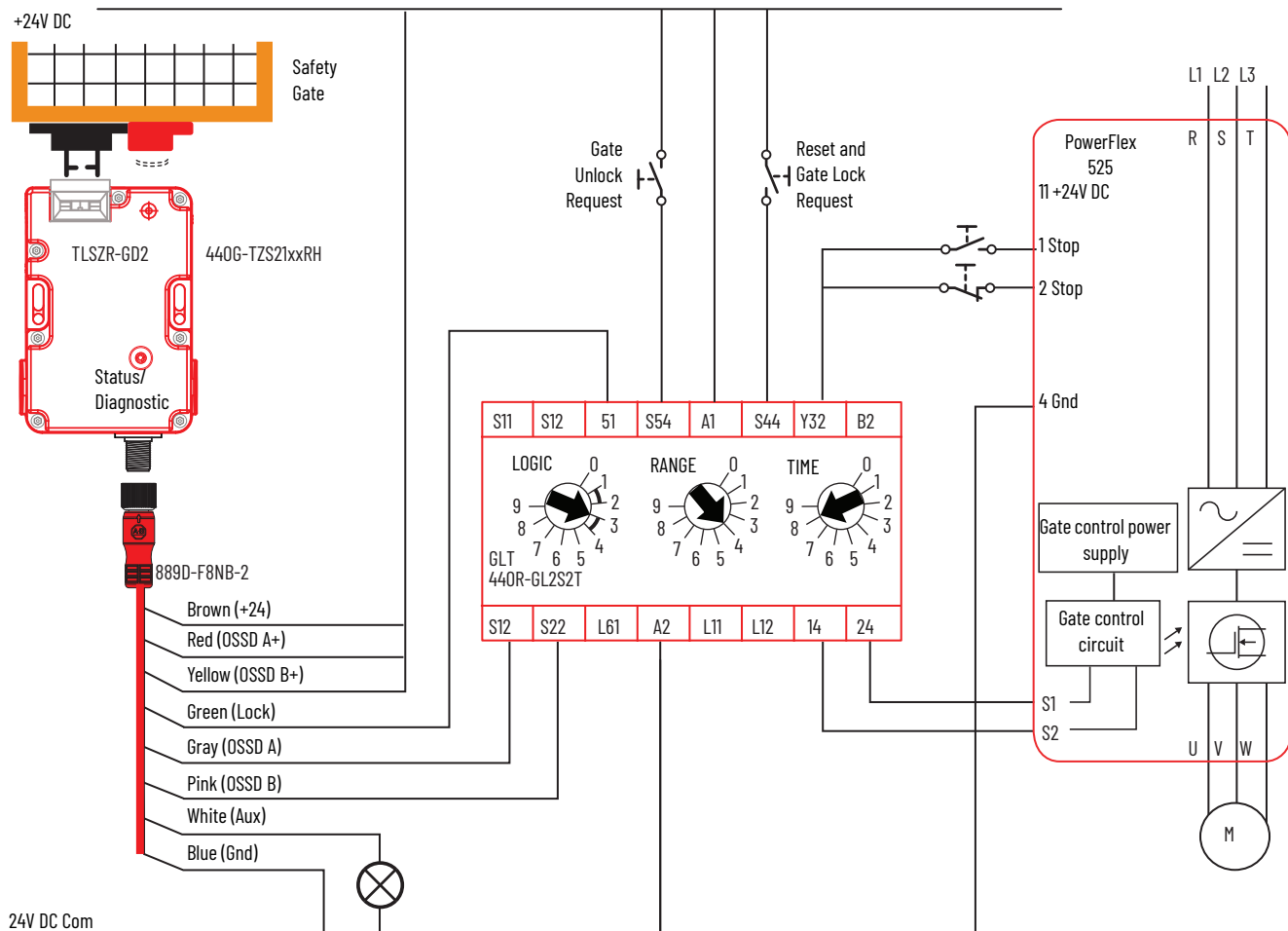

### Circuit Status as Shown

The gate is open and unlocked. The motor is off. The GLT safety relay is ready for reset. The GLT safety relay has a Logic setting of 3: (Category 1 Stop), a Range setting of 4 (10 seconds) and a Time setting of 8 (80%). The Y32 output turns off immediately; 8 seconds later, the safety outputs turn off.

The safety outputs (14 and 24) and the single wire safety output (L11) are off and the auxiliary output (Y32) is on.

#### IMPORTANT

Start the GLT logic configuration from 0 to configure 14 and 24 for use with pulse testing; the PF525 can operate with pulse-tested inputs to S1 and S2.

#### Starting

Close the gate. Press Reset and Gate Lock Request to lock the gate and turn on the GLT safety outputs. Press Start to turn on the motor.

#### Stopping

Normal production stops are performed by pressing Stop. Access through the safety gate is initiated by pressing the Gate Unlock Request. The Y32 output of the GLP safety relay turns off, which commands the PowerFlex drive to bring the motor to a stop. After the configured time delay (8 seconds) expires, the GLT safety outputs turn off, and the gate becomes unlocked. After you leave the cell and close the gate, press Reset to lock the gate and return the machine to a production state.

The circuit meets the safety requirements up to Category 3, Performance Level d in accordance with ISO 13849-1 and SIL CL 2 in accordance with IEC 62061.

## Wiring to DI and EMD Relay

The TLZ can be connected to the DI and EMD safety relays. The DI safety relay monitors the safety outputs of the TLZR guard locking switch and the EMD safety relay enables the gate to be unlocked after a configured delay time expires.

B1 is connected to B2 to allow for retriggering. If you open and close the E-stop and press Reset before the delay expires, the EMD timer resets.

Upon initial power-up, the TLSZ guard locking switch must be cycled for the DI safety relay to recognize the TLSZ OSSD signals.

In the example shown in [Figure 18](#), an E-stop initiates the machine shutdown. After an eight-second delay, the TLZR guard locking switch is allowed to be unlocked and the hazards that remain are turned off. A selector switch is required to maintain the gate in an unlock state. The risk assessment must determine the adequate time delay for the machine to achieve a safe state before unlocking the gate.

**Figure 18 - DI with EMD and TLSZR Schematic**

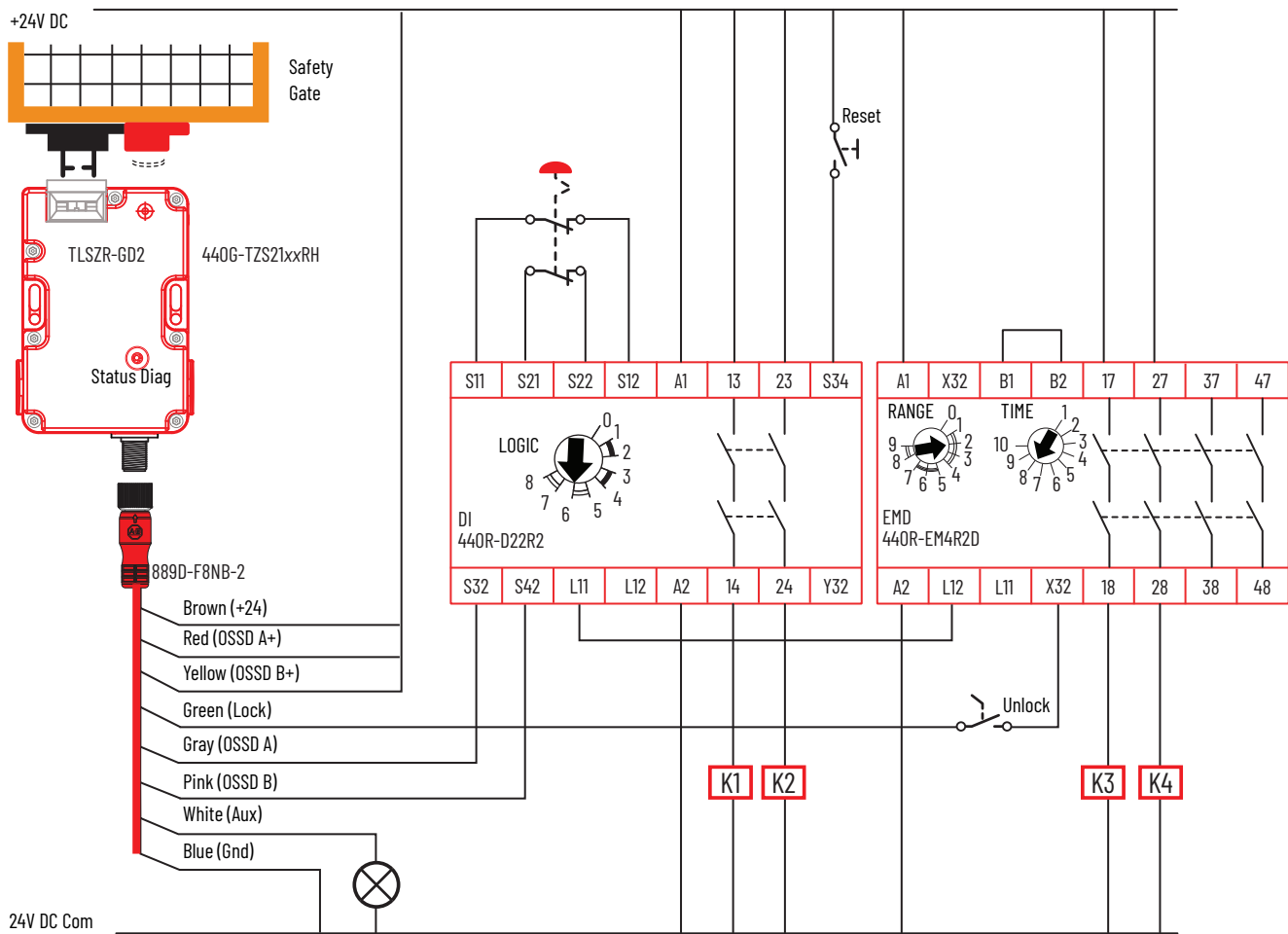

### Circuit Status as Shown

The E-stop is released. The gate is open and unlocked. K1, K2, K3, and K4 are off. The DI safety relay is configured for two inputs with monitored manual reset. The EMD safety relay is configured for 8-second off-delay; Range setting of 2 is 10 s, Time setting of 8 is 80% of the range. The X32 terminal is on because the EMD safety outputs are off.

### Starting

With the Unlock switch open, close the gate. Press Reset to lock the gate and turn on the K1...K4 safety contactors.

## Stopping

Stopping is initiated by pressing the E-stop. K1 and K2 contactors turn off immediately. The single wire safety signal from the DI (L11) to the EMD (L12) also turns off immediately, and the EMD safety relay starts the off-delay timer. After 8 seconds, contactors K3 and K4 turn off and X32 goes to 24V. The unlock switch is enabled, and the gate can be unlocked. While the gate is unlocked, the DI safety relay cannot turn the safety outputs back on. After you leave the cell and close the gate, open the unlock switch to lock the gate, and release the E-stop.

The circuit can meet the safety requirements up to Category 4, Performance Level e in accordance with ISO 13849-1 and SIL CL 3 in accordance with IEC 62061.

## Wiring to DG Relay

The TLSZR guard locking switch can be used in GuardLink® applications; the TLSZL guard locking switch cannot be used in GuardLink applications. The GuardLink system uses taps to connect a series of devices to one relay. The GuardLink system provides control and status information between the machine control system and the safety system.

[Figure 19](#) shows four TLSZR guard locking switches that are connected on two GuardLink circuits from one DG safety relay. The DG safety relay can accommodate up to 32 devices on each input. The devices can be a mix of many different safety devices. When guard locking devices are included in the GuardLink system, the lock/unlock command must come from the machine control system through the 440R-ENETR module.

See publication [440R-UM015](#) for further details.

**Figure 19 - DG with TLSZR Schematic**

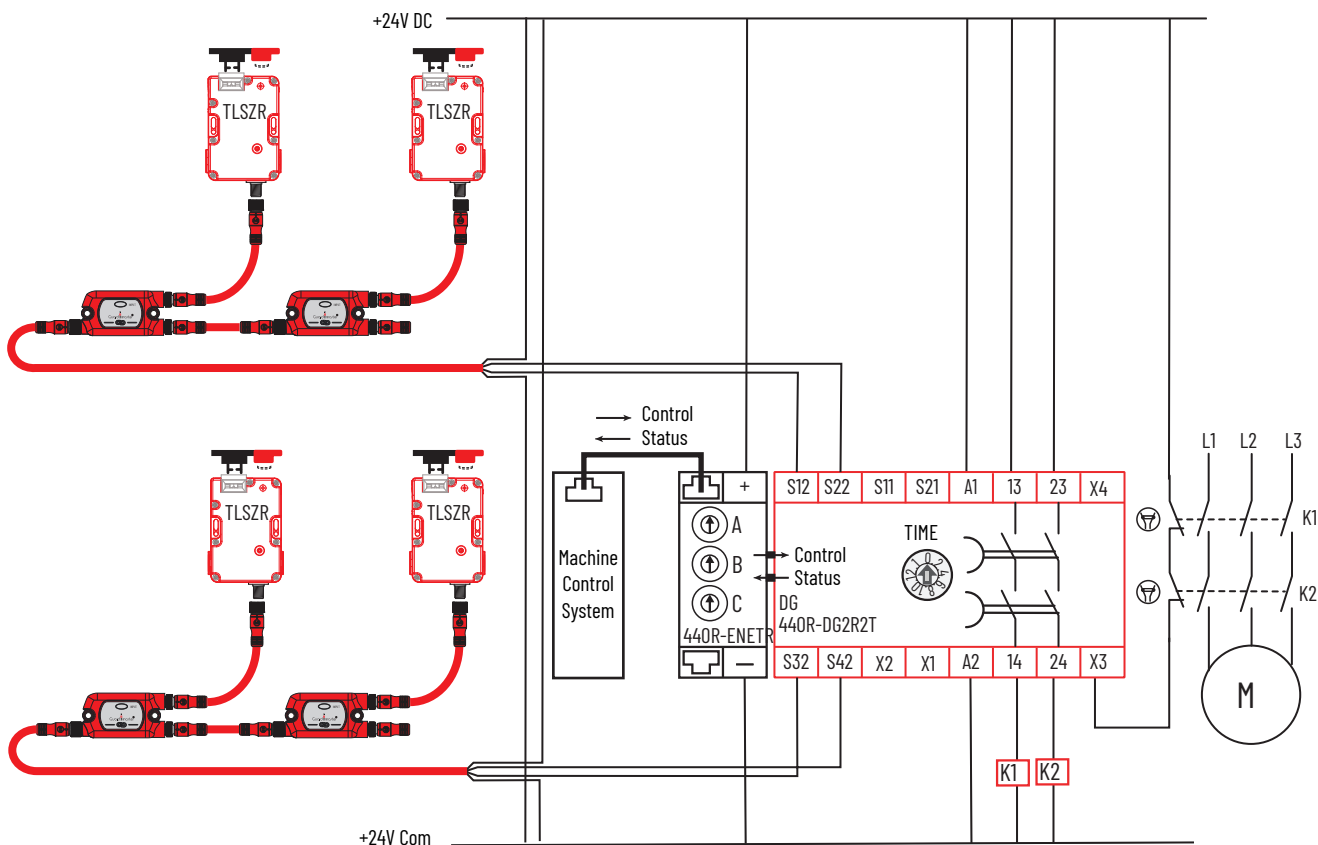

# Wiring to CR30 Software Configurable Safety Relay

The CR30 is a software-configurable relay that can easily interface with the TLSZR guard locking switch. Version 10 and later of Connected Components Workbench™ software has a locking function that is useful for guard locking applications.

Figure 20 shows an example schematic. The CR30 safety relay monitors the motor running signal from the PowerFlex® 525. When the motor is not running, the safety gate can be unlocked, and the PowerFlex 525 goes to a Safe Torque Off state.

Figure 20 - CR30 Schematic

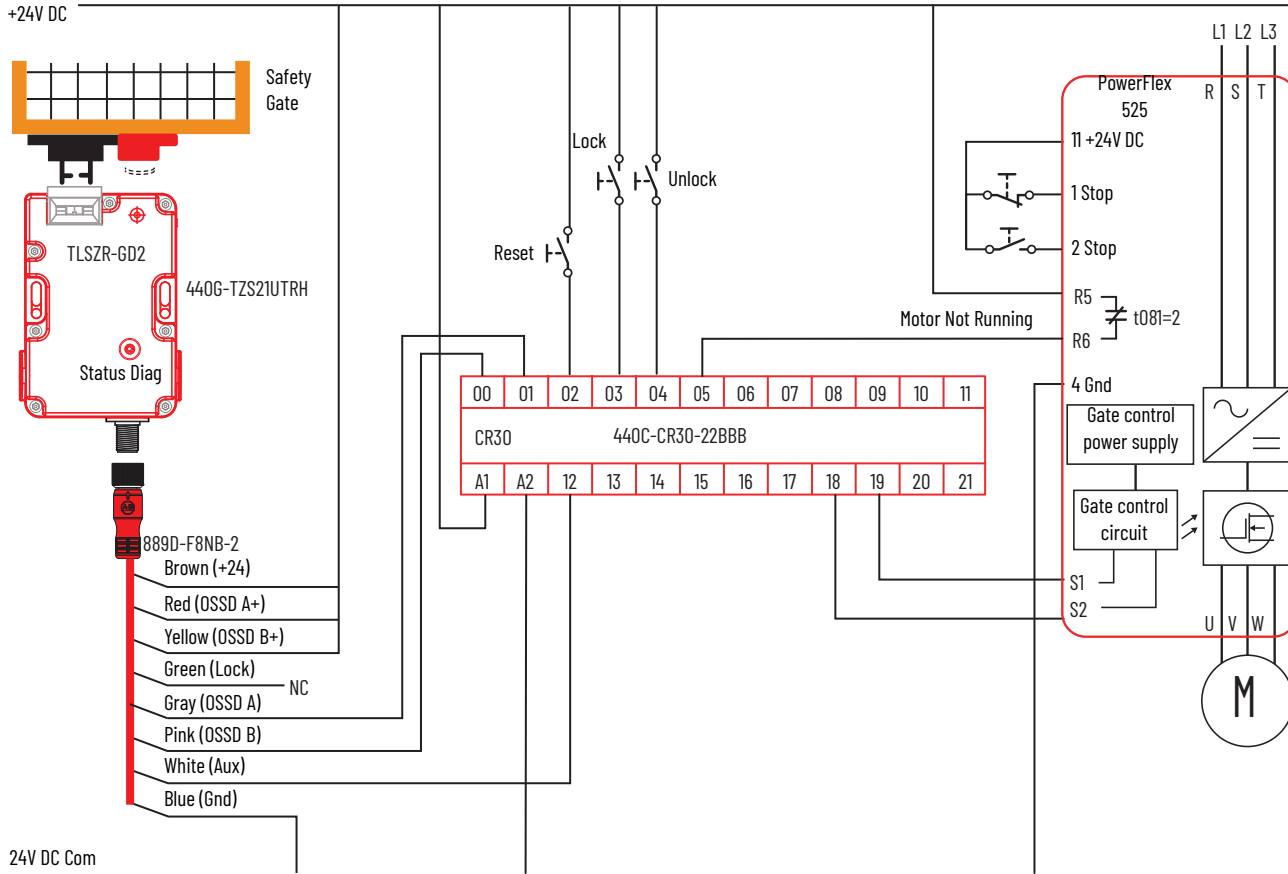

Figure 21 on page 29 shows an example CR30 safety relay configuration that works with the schematic in Figure 20.

The TLSZR OSSD outputs drive the Safe Torque Off (STO) signals of the PowerFlex 525 drive. The STO is enabled after the gate is locked and the Reset is pressed. The PowerFlex 525 STO inputs can tolerate the pulse test that is generated by the CR30 outputs.

The Lock\_Ctrl\_1 block controls the unlock command to the TLSZR guard locking switch. The unlock Stop Time delay is set to 5 seconds, and the ULR Latch (Unlock Request) is set to on. When an unlock request is made, the command is issued 5 seconds after the motor stops running, and the unlock request is latched on.

Figure 21 - CR30 Configuration in Connected Components Workbench

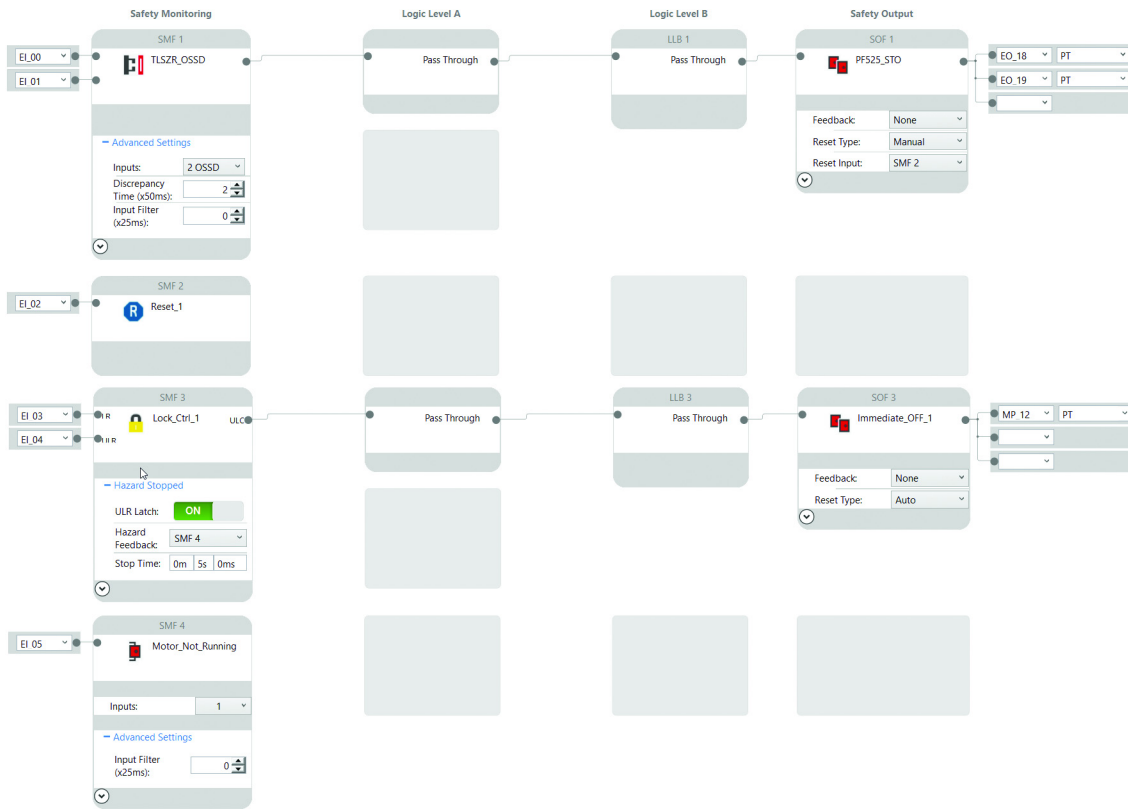



Figure 24 shows the Input Configuration tab of the 1734-IB8S Module Properties. In this example, Points 0 and 1 monitor the OSSD outputs of the TLSZL. The Type is set to Single (to allow the Logix program to detect potential faults) and the Mode must be set to Safety. Points 2 and 3 monitor the status of the output contactors K1 and K2. Set the Type to Single (to allow the program to detect potential faults). Safety pulse testing detects potential faults in the monitoring circuit. The TLSZ can operate with the Input Delay Time set to zero.

Figure 24 - 1734-IB8S Module Properties - Input Configuration

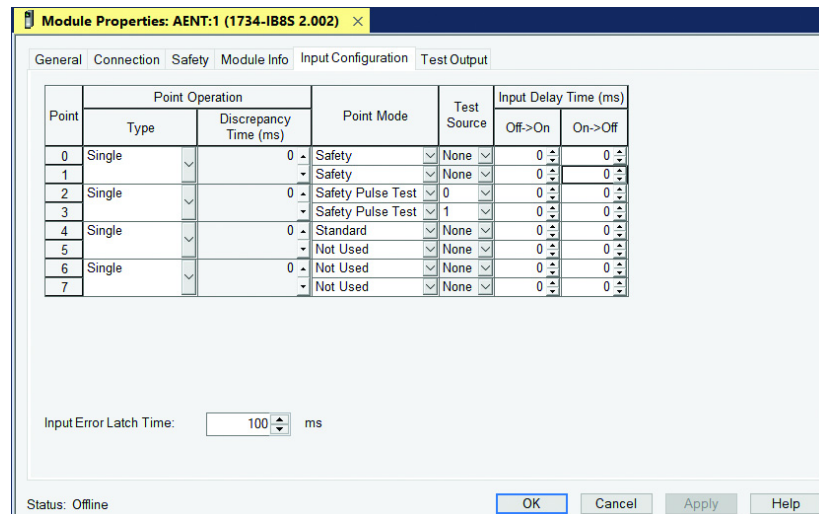

Figure 25 shows the Test Output tab of the 1734-IB8S Module Properties. In this example, Points 0 and 1 are set to pulse test as these points help check the integrity of contactors K1 and K2. Points 2 and 3 are set to Standard. Point 2 is the lock command, and Point 3 applies power to the TLSZL and supplies power to the OSSD inputs. By setting it to standard, you can programmatically turn Points 2 and 3 off and on.

Figure 25 - 1734-IB8S Module Properties - Test Output

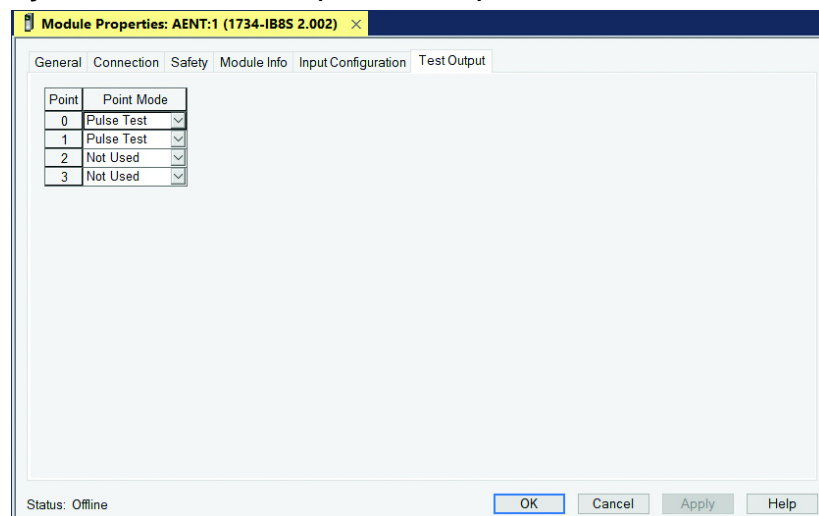

Figure 26 shows the General Tab of the 1734-OB8S Module Properties. The Output Data must be set to Safety, as it is controlling the output safety contactors.

Figure 26 - 1734-OB8S Module Properties - General

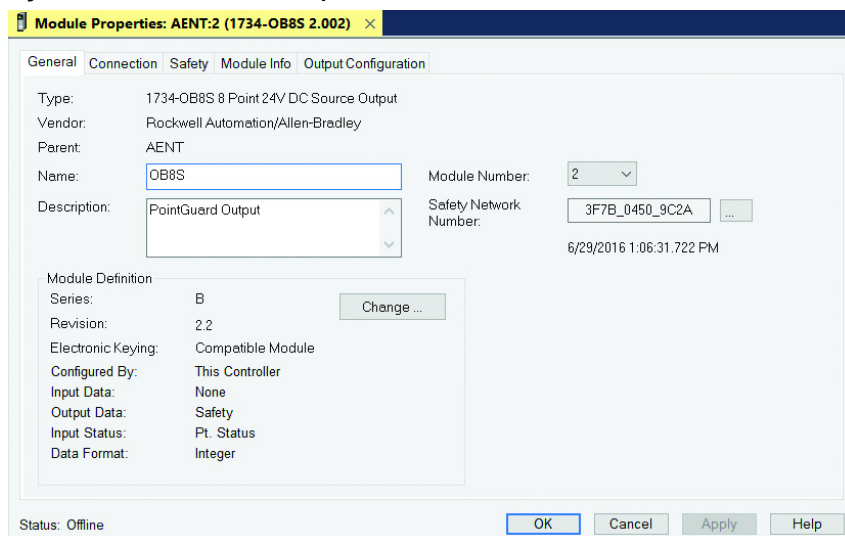

Figure 27 shows the Output Configuration tab of the 1734-OB8S Module Properties. Points 0 and 1 drive the output contactors K1 and K2. The point Types are set to Dual, and the Modes are set to Safety.

Figure 27 - 1734-OB8S Module Properties - Output Configuration

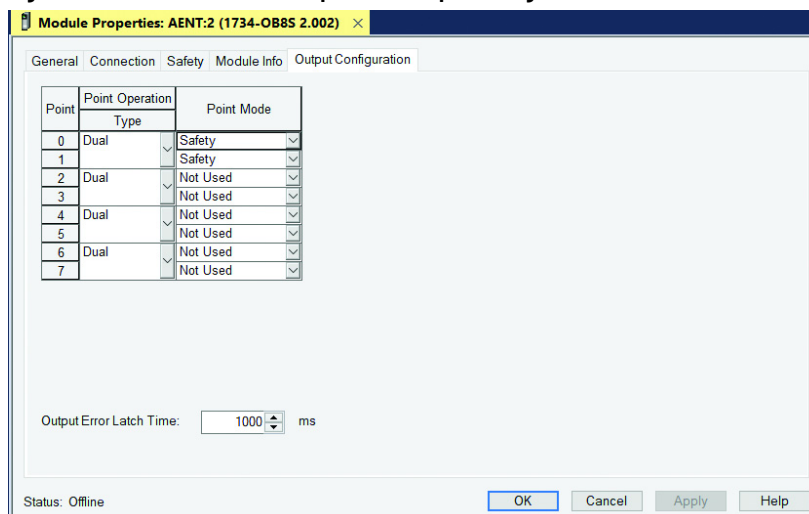

Figure 28 on page 33 shows an example logic program. A Dual Channel Input Stop function block monitors the TLSZL and a Configurable Redundant Output function block controls two contactors. This example can be used as a starting point for implementation; you must incorporate additional logic that is based on the risk assessment for the machine.

Figure 28 - Studio 5000® Example Logic Program



## Wiring to 1732 ArmorBlock

The TLSZ guard locking switch can be connected to a 1732ES or 1732DS ArmorBlock® module by using a catalog number 871A-TS5-DM1 field attachable connector. The catalog number 889D-F8NB cordset has 24-AWG wires that connect to one pin. An example schematic is shown in [Figure 29](#).

You can also use an 871A-TS8-D1 field attachable connector at the TLSZ guard locking switch and a 5-wire cordset (catalog number 889D-M5NC-x).

**Figure 29 - ArmorBlock Schematic**

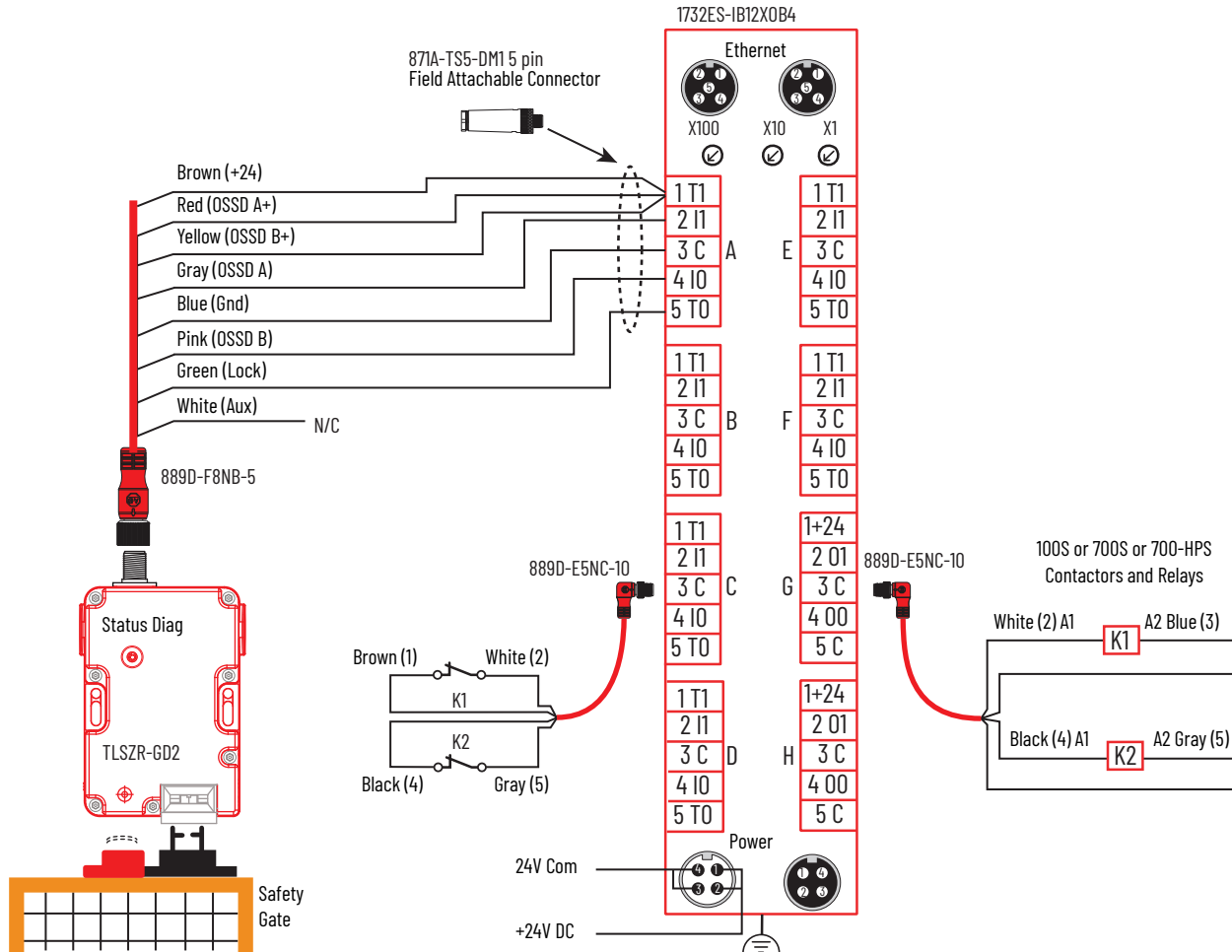

[Figure 30 on page 35](#) shows the General Tab of the ArmorBlock Module Properties. The Input Status must be set to Combined Status – Muting and the Output Data must be set to Combined.

Figure 30 - Module Properties - General

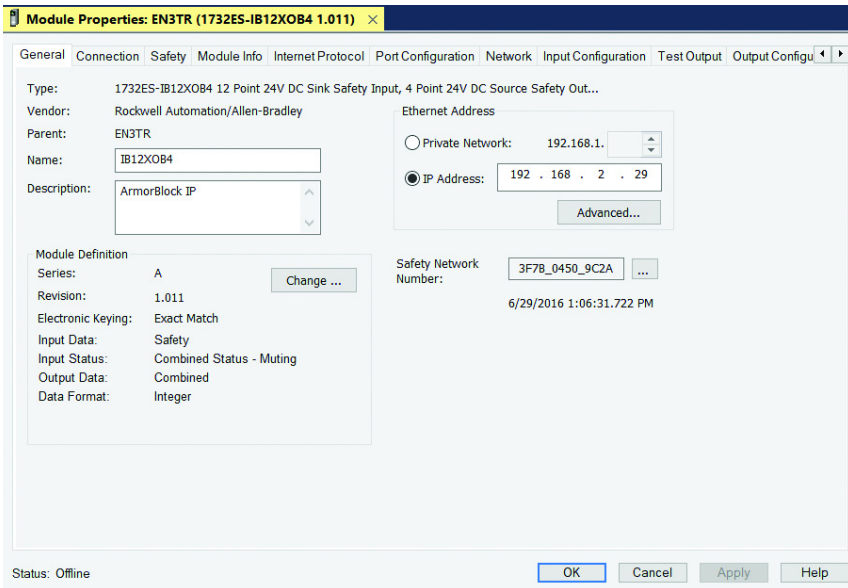

Figure 31 shows the Input Configuration tab of the ArmorBlock Module Properties. In this example, Points 0 and 1 monitor the OSSD outputs of the TLSZR guard locking switch. The Type is set to Single (to allow the Logix program to detect potential faults), and the Mode must be set to Safety. Points 4 and 5 monitor the status of the output contactors K1 and K2. Set the Type to Single to allow the Logix program to detect potential faults. The safety pulse test is used to detect potential faults in the monitoring circuit.

Figure 31 - Module Properties - Input Configuration

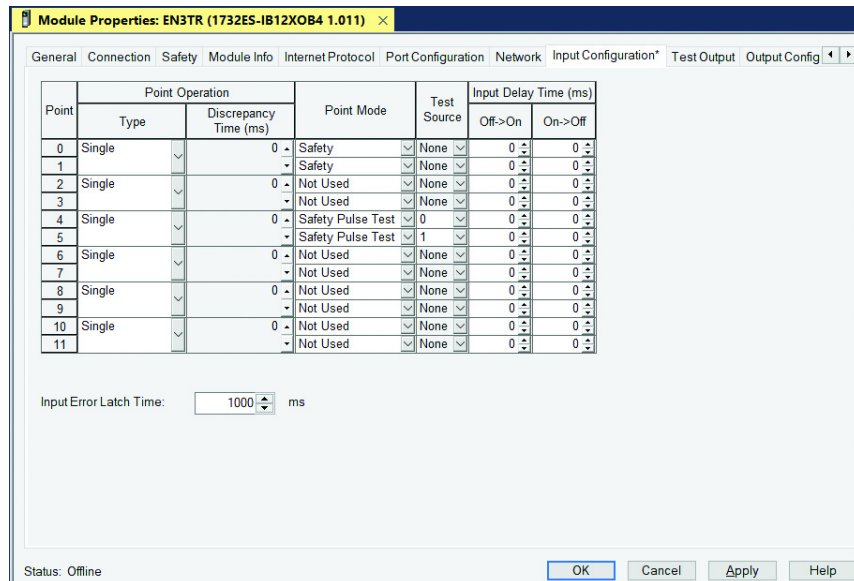

Figure 32 shows the Test Output tab of the ArmorBlock Module Properties. In this example, Points 0 and 1 are set to Standard. The Standard setting allows the program to control these two points. Point 0 applies power to the TLSZR guard locking switch. By setting it to Standard, you can programmatically turn this point off and on if the TLSZ guard locking switch has a fault condition. Point 1 is the lock/unlock command. In this example, the TLSZ is a PTR type, so 24V unlocks the switch. Use Points 4 and 5 to monitor the contactor outputs and are set to pulse test.

Figure 32 - Module Properties - Test Output

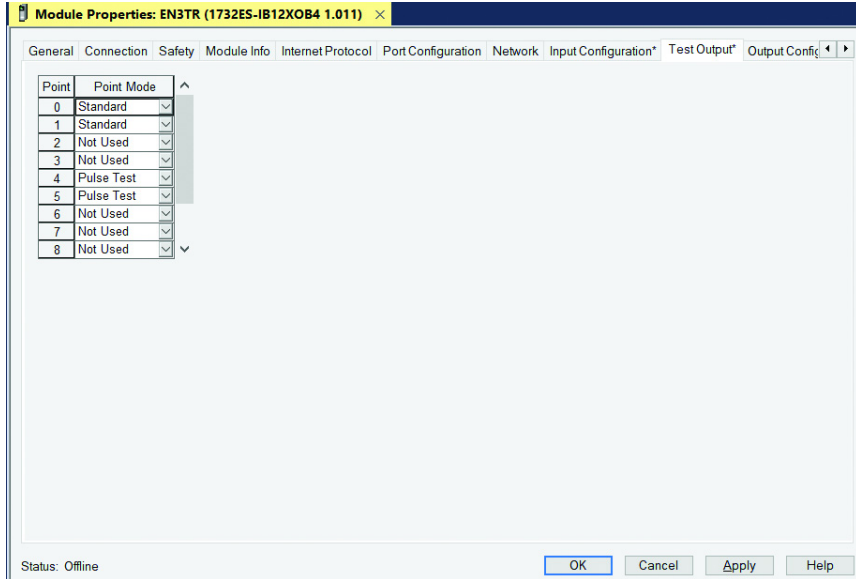

Figure 33 shows the Output Configuration tab of the ArmorBlock Module Properties. Points 0 and 1 drive the output contactors K1 and K2. The point Types are set to Dual, and the Modes are set to Safety.

Figure 33 - Module Properties - Output Configuration

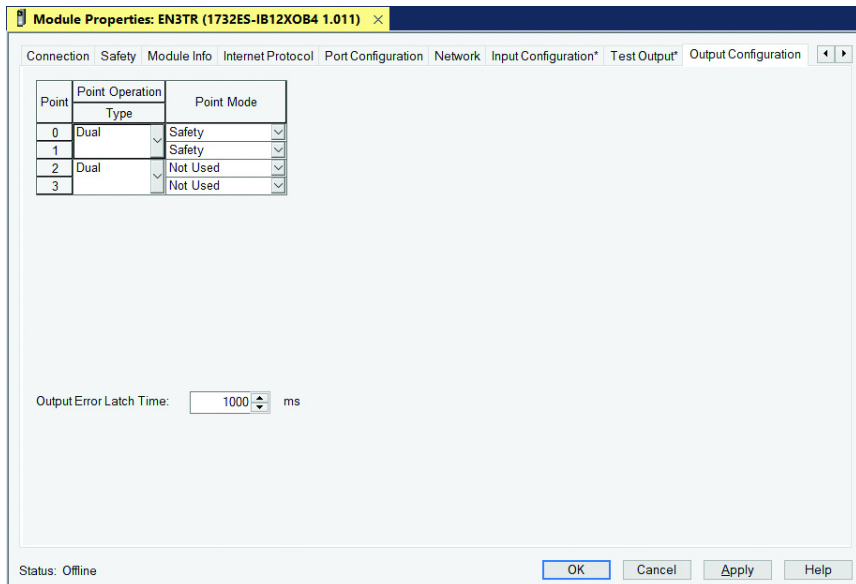
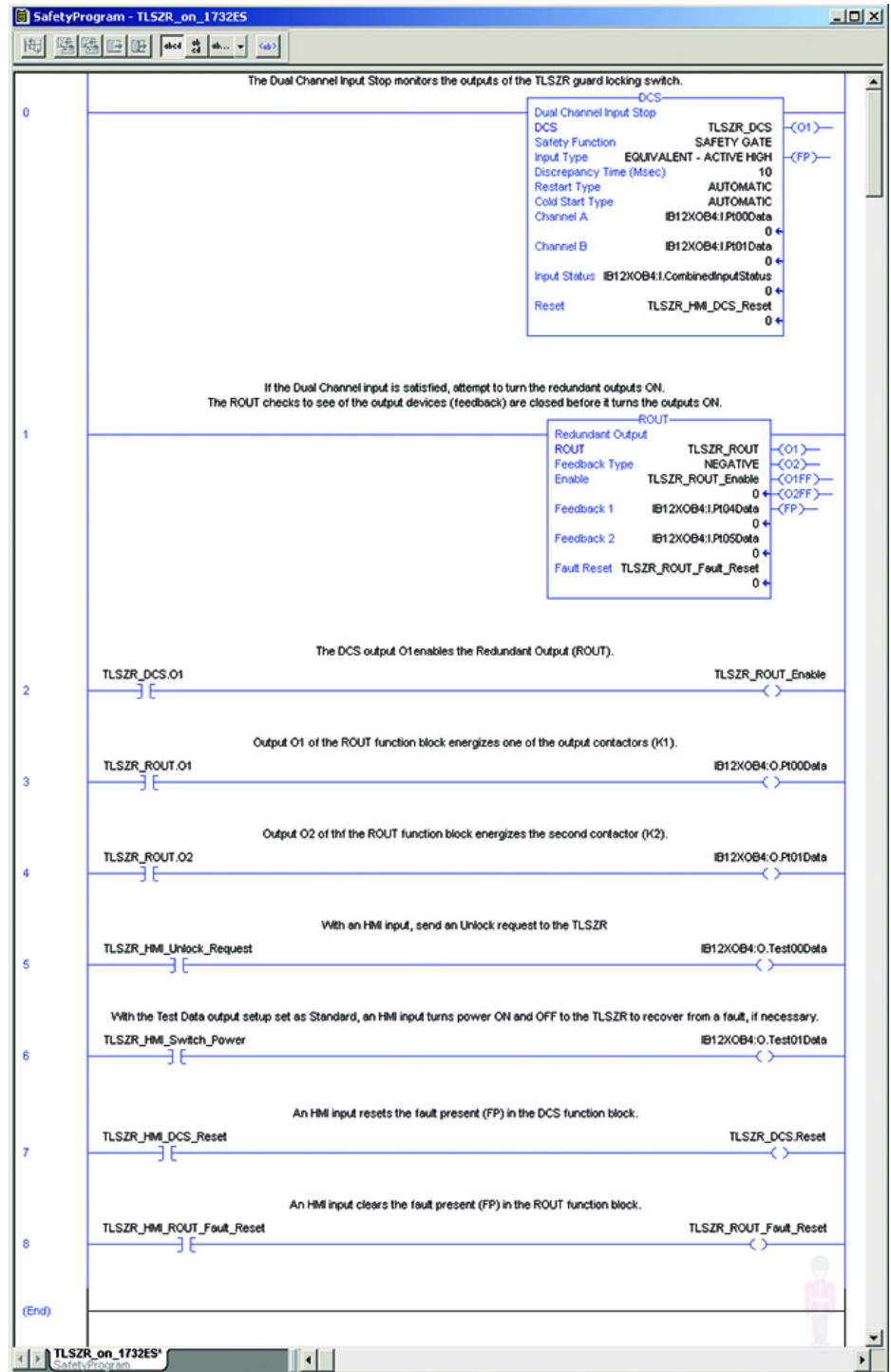

Figure 34 shows an example program. A Dual Channel Input Stop function block monitors the TLSZR guard locking switch and a Configurable Redundant Output function block controls two contactors. This example can be used as a starting point for implementation; based on the risk assessment for the machine, you can incorporate additional logic.

Figure 34 - Example Studio 5000 Program



**Notes:**

## Diagnostics and Troubleshooting

Persons who are trained in the safety of machine systems must conduct the troubleshooting procedures. This training includes knowledge of all sources of energy (for example electrical, pneumatic, safety, thermal, and others).

To troubleshoot TLSZ guard locking switches, observe the status indicator on the guard locking switch and follow the flow diagram in [Figure 35 on page 40](#).

### Tools Needed

#### Required Tools

- T20 security-Torx screwdriver bit. The security Torx has a hollow center. This bit is required to remove the cover of the TLSZ guard locking switch.
- Medium-sized flat screwdriver for terminal screws, to remove terminal blocks, and to configure the guard locking switches on the front face of the relays.
- Digital multimeter (DMM) to measure signal levels and resistance.

#### Optional Tools

- Oscilloscope – Dual or four-channel storage scope to view input and output signals and to capture signals and noise transients.
- Metal paper clips – To insert into the terminals and allow connection of scope probes to terminals.

## Flowchart

[Figure 35](#) shows a flow diagram to help diagnose the condition of the TLSZ guard locking switch.

**Figure 35 - Troubleshooting Flow Diagram**

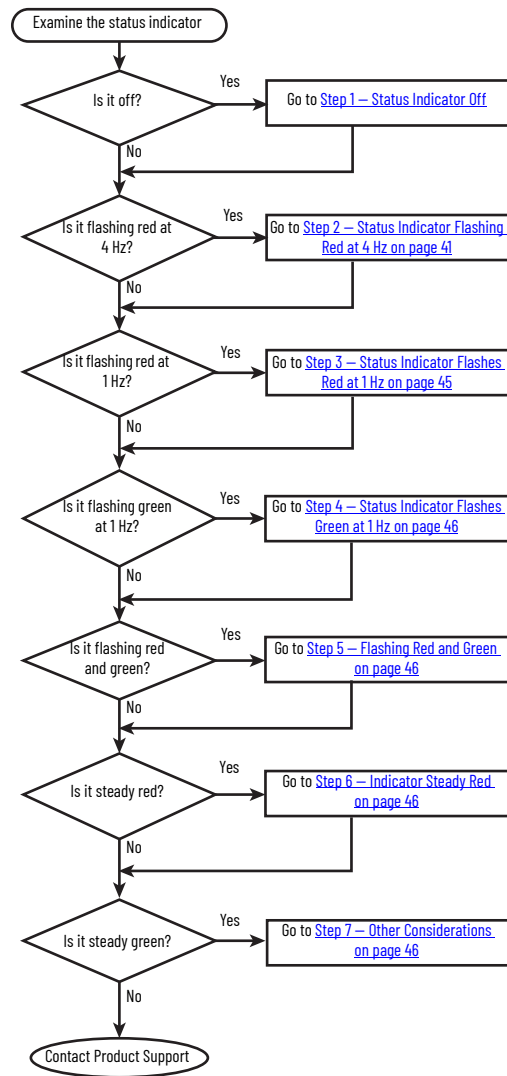

### Step 1 – Status Indicator Off

When the status indicator is off, the TLSZ guard locking switch is not connected properly to either the 24V power supply or ground.

1. Use the Torx screwdriver to remove the TLSZ guard locking switch cover.
2. Use a digital multimeter (DMM) to measure the voltage at the power supply terminals (blue wire is 0V and brown wire is plus), as shown in [Figure 36 on page 41](#).

The voltage must measure between 20.4...26.4V DC.

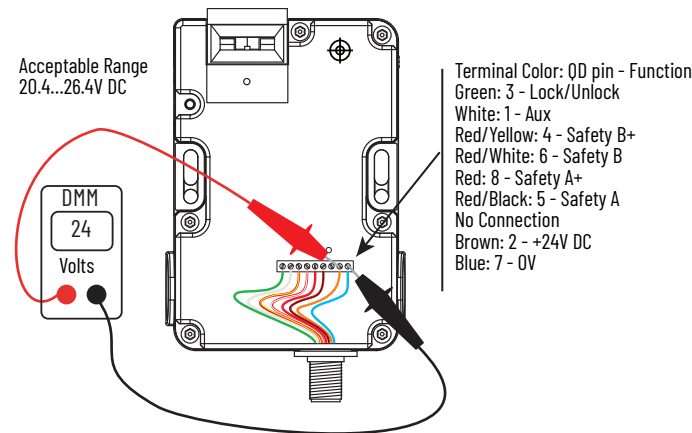
**Figure 36 - Measure the Voltage at the Power Supply Terminals**

If 24V is present at the wiring terminals, check that the wires are stripped and the terminal screws are tight. If the wires are functional, replace the guard locking switch.

If 24V is not present at the terminals, check the power supply and the wiring up to the TLSZ guard locking switch.

## Step 2 – Status Indicator Flashing Red at 4 Hz

The status indicator flashes red at 4 Hz when an inconsistency is detected with the RFID sensor. A number of scenarios can cause this fault indication.

### Wrong Target

The TLSZ guard locking switch is configured to detect a specific target. If a non-configured target is presented to the TLSZ guard locking switch, the TLSZ goes into Fault mode and its status indicator flashes red at 4 Hz.

To correct this condition:

1. Replace the incorrect target with a correct target.
2. Cycle the power to clear the fault.

From the factory, the TLSZ guard locking switch is not configured to detect any target. You must configure the TLSZ guard locking switch to detect a target. The configuration can be a one-time event, or the TLSZ guard locking switch can be configured to learn up to eight different targets. The TLSZ guard locking switch can only recognize one target. If the target gets damaged, the TLSZ guard locking switch can be configured to learn another target, if the initial configuration is set to multi-time learning, see [Commissioning Errors on page 19](#).

### Missing Target

If the actuator is inserted into the TLSZR guard locking switch without the target present, the status indicator flashes red at 4 Hz.

To correct this condition:

1. Remove the actuator from the guard locking switch.
2. Cycle power to the TLSZR guard locking switch.
3. Mount the target next to the actuator as shown in [Figure 37 on page 42](#).

Insert the actuator/target into the guard locking switch.

## Target Not Mounted Correctly

If the actuator is mounted incorrectly, the TLSZ can operate correctly, but with reduced tolerance to misalignment of the target. The status indicator intermittently goes to a fault state with the status indicator flashing red at 4 Hz.

To correct this condition:

1. Remove the actuator/target from the guard locking switch.
2. Cycle power to the TLSZ guard locking switch to clear the fault.
3. Mount the target next to the actuator as shown in [Figure 37](#).
4. Insert the actuator/target into the guard locking switch.

**Figure 37 - Mounting of Target and Actuator**

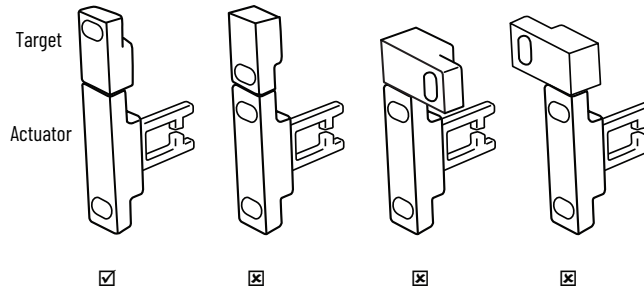

## Pair Proximity

If you mount a TLSZ safety switch close to another safety switch, 440G-LZ guard locking switch, or 440N-Z SensaGuard™ switch, the two inductive fields interact causing crosstalk, which results in nuisance faults and false operation.

To correct this condition:

1. Mount the neighboring switches at least the minimum distance from the edge of the TLSZ guard locking switch.
  - Series E and earlier: 200 mm (8 in.)
  - Series F and later: 75 mm (3 in.)
2. Cycle power to the TLSZ guard locking switch to clear the fault.

## Mechanical Pressure on Safety Gate

If a mechanical load (pressure) is applied to the gate during unlocking, the TLSZR guard locking switch goes to a fault mode. The status indicator flashes green three times and then red once. It repeats this process for 10 seconds, and then the status indicator flashes red at 4 Hz. Firmware 1.003 and earlier have a 10-second limit. Firmware 1.004 attempts to lock for 10 minutes.

1. Check the allowable spacing between the TLS and mechanical gate stop.
2. Adjust the spacing to be between 1 mm (0.04 in.) and 4 mm (0.16 in.) between the actuator and the metal guide as shown in [Figure 38 on page 43](#).
3. Cycle power to the TLSZ guard locking switch to clear the fault.

The safety gate needs some freedom to move when locked.

Figure 38 - Clearance in Closed Position [mm (in.)]

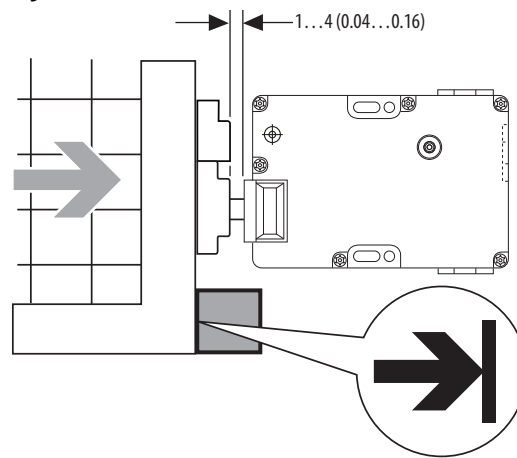

## Long Wiring

Long input wiring adds resistance and decreases the supply voltage to the guard locking switch and reduces the safety OSSD outputs. The size of the wire also makes a difference; smaller wires have higher resistance.

[Figure 39](#) shows the typical TLSZ guard locking switch test pulses when connected to a resistive load with short [2 m (6.56 ft)] wiring. The test pulses are about 25 ms wide.

---

**IMPORTANT** The OSSD outputs are about 23V and the test pulses go to zero volts.

---

Figure 39 - TLSZ Test Pulses Into a 1K Resistive Load

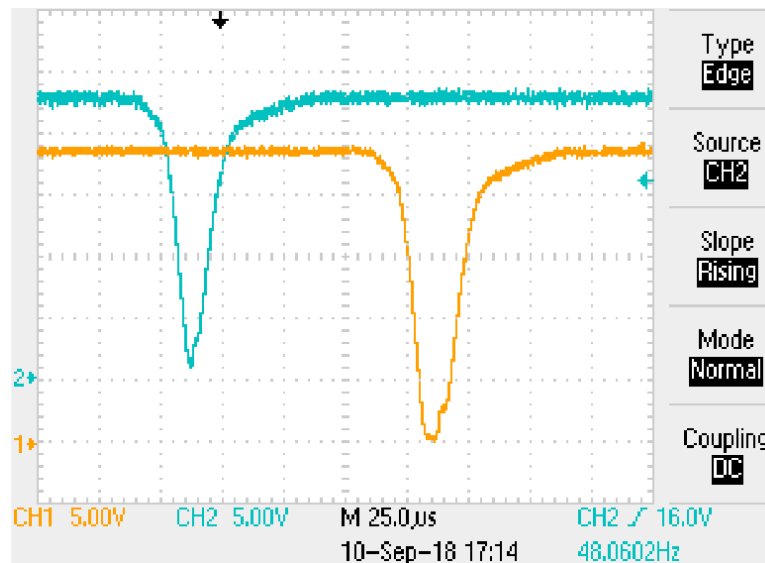

In [Figure 40 on page 44](#), TLSZR and GSR-SI guard locking switches operate successfully with long wiring. The OSSD outputs drop to approximately 21V and the test pulses only drop to approximately 8V (not 0V).

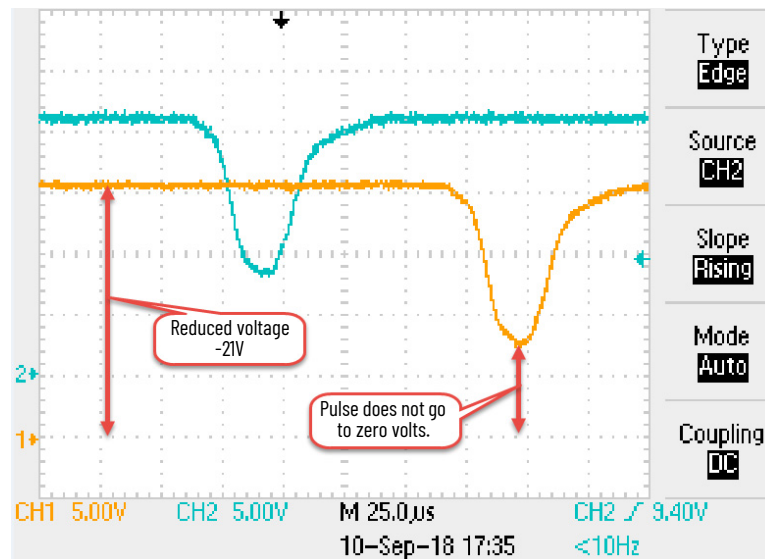
Figure 40 - Effect of 300  $\Omega$  of Wire Resistance Going Into a GSR-SI Safety Relay

## Voltage Supply Dips

When the TLSZ guard locking switch solenoid energizes, it causes a 350 mA inrush current on the power supply wire. If multiple TLSZ guard locking switches energize simultaneously, the voltage supply can dip below the 20.4V voltage specification and cause the guard locking switch to go into Fault mode.

Voltage drop is by:

1. The number of guard locking switches being energized simultaneously.
2. The power supply wire size.
3. The wire length.

### IMPORTANT

The lock/unlock command on the TLSZ guard locking switch is not like the older TLS1, TLS2, and on the TLSZ (both Power to Lock and Power to Release) is a logic level signal; about 3...5 mA. The power to energize the solenoid is provided by the brown power supply wire.

To avoid the power supply dip, we recommend that you stagger the lock/unlock command to successive guard locking switches by at least 170 ms.

## Rapid Locking

The TLSZL Power to Lock switches cannot withstand rapid locking and unlocking. This action results in the indicator flashing red at 4 Hz. Although TLSZR Power to Release switches are more tolerant to rapid unlocking/locking, they can also go to a fault state with the indicator flashing red at 4 Hz.

We recommend you check that the locking operation frequency is no faster than 1 Hz with a 50% duty cycle (500 ms lock, 500 ms unlock).

## Step 3 – Status Indicator Flashes Red at 1 Hz

This status indicates that an undetermined fault has occurred.

Cycle the power. If the guard locking switch does not recover, cycle it again. If the guard locking switch does not recover, then run a separate cable directly from the power supply to the guard locking switch. This cable can run on the floor away from any extraneous signals. You can also provide a temporary selector switch to execute the lock/unlock command.

- Case 1: Switch Operates OK. Check the routing of the cable from the power supply to the guard locking switch. Be sure of adequate separation of guard locking switch cabling to sources of electromagnetic noise, such as drives and motion systems.
- Case 2: Switch Faults. If the guard locking switch fails with the cabling on the floor (clear of all electromechanical noise), then replace the guard locking switch.

## Capacitive Loading

The OSSD outputs of the TLSZ guard locking switch use pulse testing to detect faults. The pulse testing is subjected to the capacitive loading of the cabling (longer cabling creates additional capacitance) and capacitance from the device to which it is connected.

Cable capacitive loading is not an intermittent issue. Once resolved, the capacitance can remain unchanged until conditions, such as cabling changes, occur.

Use an oscilloscope to measure the pulse tests. [Figure 41](#) shows the typical effect; the curved leading edge indicates capacitive loading.

The TLSZR guard locking switch can withstand a capacitive load up to 375 nF. Higher capacitance causes the OSSD outputs to turn off and the indicator flashes red at 1 Hz. Higher levels of capacitance can be tolerated by adding a 10K resistor from the OSSD signal to ground.

**Figure 41 - Typical Capacitive Effect on Pulse Tests**

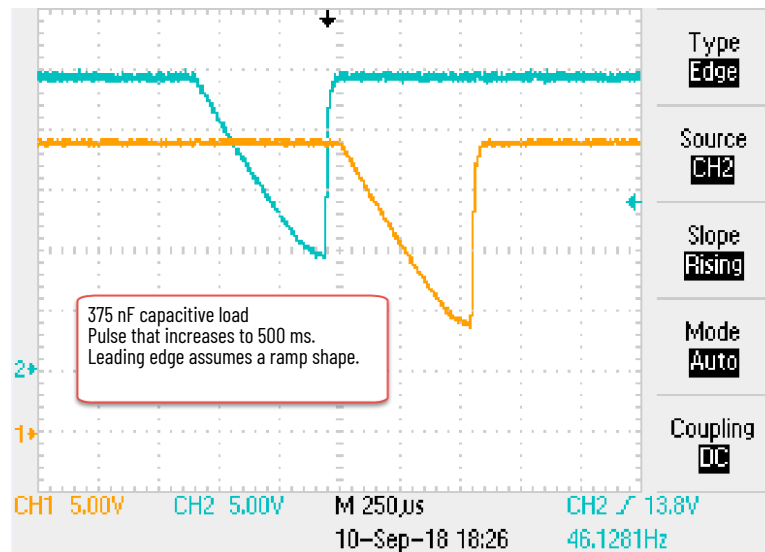

## Step 4 – Status Indicator Flashes Green at 1 Hz

When the status indicator is flashing green at 1 Hz, the guard locking switch is indicating that it is waiting for 24V to be applied to the OSSD A+ and OSSD B+ input signals.

Upon power-up, the TLSZ guard locking switch performs internal checks. During this time, the status indicator flashes green three times, shows steady red for about 2 seconds. If the OSSD A+ and OSSD B+ inputs are not connected to 24V, the status indicator then flashes green at 1 Hz.

### Corrective Action

1. If you have multiple guard locking switches that are connected in series, check the OSSD outputs of the prior guard locking switch.
  - a. If the prior guard locking switch is flashing green, go to then next prior guard locking switch to determine why its OSSD outputs are off.
  - b. If the TLS is the only guard locking switch or the first guard locking switch in a series connection of switches, check the power supply connections of OSSD A+ (red wire) and OSSD B+ (yellow wire).

## Step 5 – Flashing Red and Green

The TLSZ guard locking switch was initially configured for multi-time use. The flashing red and green indicator indicates the number of configurations that can be completed, see [Commissioning on page 17](#).

## Step 6 – Indicator Steady Red

The steady red indicator occurs when specific faults have not been detected.

1. Try to cycle power.
2. Remove the cable and reconnect the guard locking switch to a separate cable and use the existing power supply.
  - If the guard locking switch recovers, check the existing cable routing to verify that the guard locking switch cable is not along motor or other high-noise wiring. Also check the grounding scheme, the 0V of the guard locking switch must be very close to the safety logic device to which it interfaces.
  - If the guard locking switch does not recover, proceed to [step 3](#).
3. Remove the guard locking switch from the installation and apply a bench test circuit.
  - If the guard locking switch still exhibits a steady red indicator, replace the guard locking switch.
  - If the guard locking switch recovers, then re-examine the cable routing and the grounding scheme.

## Step 7 – Other Considerations

### Distribution Block

The TLZ guard locking switch can be connected to the catalog number 898D distribution block. The distribution block is available with either four or eight ports. An example with eight ports is shown in [Figure 42 on page 47](#). This application requires special considerations:

1. The cable lengths in this example are all 30 m (98.4 ft) long. The cable length causes a 1.5V drop in power at the guard locking switch.
2. If the power supply is set to 24V, the voltage at the terminals inside each guard locking switch is 22.5V.

## Common Lock Signal

The lock/unlock command is simultaneously applied to all eight guard locking switches. Each guard locking switch has a 300 mA nominal (350 mA max) inrush current that lasts about 110 ms (see [Figure 43](#)). With all eight guard locking switches simultaneously locked/unlocked, the inrush current is 2.4 A. The power supply must be able to accommodate this inrush.

**Figure 42 - TLSZ Guard Locking Switch with 898D Distribution Block**

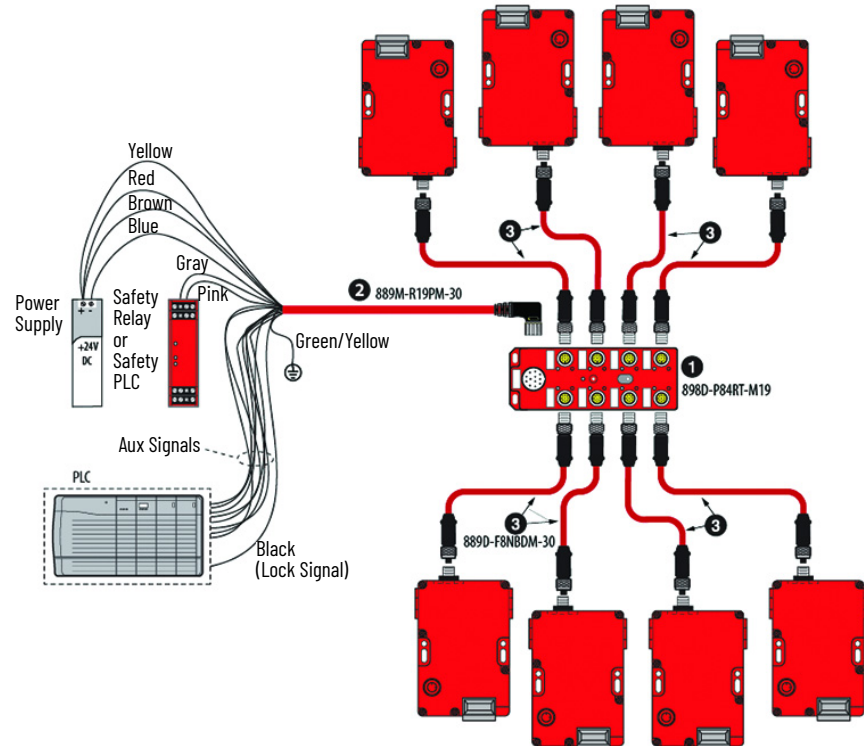

**Figure 43 - Inrush Current on the Power Supply at the Guard Locking Switch**

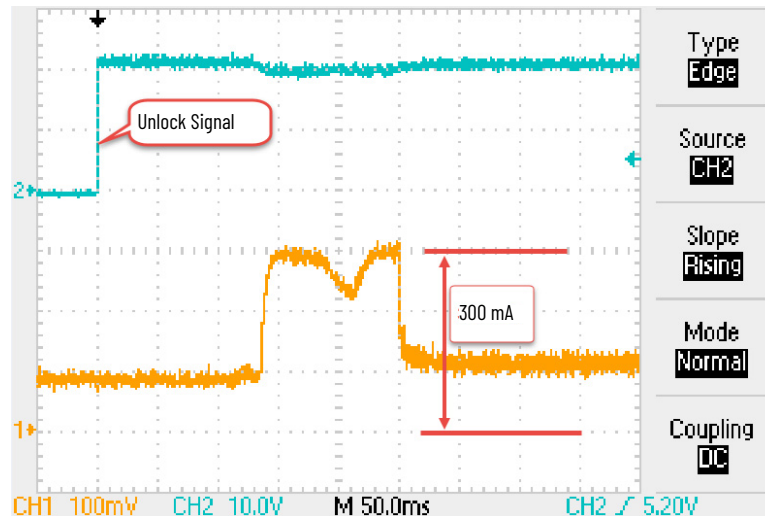

## GSR Relays on Power-up

Upon power-up, the Guardmaster® safety relays (GSR) input does not recognize the status of the TLSZ guard locking switch outputs; the IN1 indicator remains off. The TLSZR guard locking switch must be unlocked and then locked. Then the GSR relay recognizes the OSSD outputs of the TLS. This sequence only occurs on power-up and is a function of the GSR (not the TLSZ guard locking switch).

**Notes:**

## Specifications

### Safety Ratings

Attribute	440G-TZS2IUPRH, 440G-TZS2IUPLH, 440G-TZS2IUTRH, 440G-TZS2IUTLH
Standards	IEC 60947-5-3, IEC 60947-5-1, IEC 62061, IEC 61508, ISO 13849-1, ISO 14119
Category per ISO 13849-1	4
Performance Level per ISO 13849-1	PLe, includes guard door position and lock monitoring
SIL claim limit per IEC 62061	3
PFHd [1/h]	1.70E-09
Proof test interval	20 years
Certifications	CE Marked for all applicable directives, UKCA Marked for all applicable regulations, cULus Listed (UL 508), and TÜV Certified

### Operating Characteristics

Attribute	440G-TZS2IUPRH, 440G-TZS2IUPLH, 440G-TZS2IUTRH, 440G-TZS2IUTLH				
TLSZR-GD2	Power to Release				
TLSZL-GD2	Power to Lock				
Assured locking distance	13 mm (0.51 in.) max target distance 4 mm (0.16 in.) max clearance between actuator base and switch in the door closed position				
Torque for M5 mounting	1.4 N•m (12.39 lb•in)				
Torque for cover mounting	1.2 N•m (10.62 lb•in)				
Locking force $F_{max}$	<ul style="list-style-type: none"> <li>Plastic pins: 1950 N (488 lb)</li> <li>Steel bolts: 2600 N (585 lb)</li> </ul>				
Locking force $F_{zh}$ per EN/ISO 14119	<ul style="list-style-type: none"> <li>Plastic pins: 1500 N (337 lb)</li> <li>Steel bolts: 2000 N (450 lb)</li> </ul>				
Maximum output current (all outputs)	200 mA				
Current consumption	<ul style="list-style-type: none"> <li>Solenoid not energized, no output load: 75 mA</li> <li>Solenoid energized, no output load: 120 mA</li> <li>Inrush current: 350 mA</li> </ul>				
Solenoid duty cycle	<table border="1"> <tr> <td>Series E and earlier</td> <td>100%</td> </tr> <tr> <td>Series F and later</td> <td>33%</td> </tr> </table>	Series E and earlier	100%	Series F and later	33%
Series E and earlier	100%				
Series F and later	33%				
Off-state current	< 0.5 mA DC				
Maximum number of switches connected in series	Unlimited				
Operating voltage $U_e$	24V DC +10% / -15%, Class 2 Source Required				
Frequency of solenoid operating cycle	1 Hz, max				
Actuation speed	160 mm/s (6.29 in/s), max 100 mm/min (3.94 in/min), min				
Response time (off)	<table border="1"> <tr> <td>Series E and earlier</td> <td>75 ms first switch, 25 ms additional for each switch</td> </tr> <tr> <td>Series F and later</td> <td>45 ms first switch, 10 ms additional for each switch</td> </tr> </table>	Series E and earlier	75 ms first switch, 25 ms additional for each switch	Series F and later	45 ms first switch, 10 ms additional for each switch
Series E and earlier	75 ms first switch, 25 ms additional for each switch				
Series F and later	45 ms first switch, 10 ms additional for each switch				
Utilization Category per IEC 60947-5-2	DC-13, 24V 200 mA				
Impulse withstand voltage $U_{imp}$	250V				
Protection class	2				
Mechanical life	1,000,000 cycles				

## Environmental

Attribute	440G-TZS2IUPRH, 440G-TZS2IUPLH, 440G-TZS2IUTRH, 440G-TZS2IUTLH	
Operating temperature	-10...+60 °C (14...140 °F)	
Operating humidity	5...95%	
Risk time, max <sup>(1)</sup>	Series E and earlier	60 ms
	Series F and later	45 ms
Rated insulation voltage Ui	500V	
Enclosure ingress rating	NEMA 3, 4X, 12, 13, IP66, IP67, IP69K	
Shock per IEC 68-2-27	30 g, 11 ms	
Vibration IEC 68-2-6	10...55 Hz, 0.35 mm	
Radio frequency	IEC 61000-4-3 IEC 61000-4-6	
Pollution degree	3	
Altitude, max	2000 m (6562 ft)	

(1) If the RFID door target moves outside of the operating distance, the safety outputs are deactivated

## General

Attribute	440G-TZS2IUPRH, 440G-TZS2IUPLH, 440G-TZS2IUTRH, 440G-TZS2IUTLH
Material	<ul style="list-style-type: none"> <li>Housing: UL Approved glass-filled PBT</li> <li>Actuator: Stainless steel</li> <li>Target: UL Approved glass-filled PBT</li> </ul>
Connection	M12 8-pin connector
Protection type	Short circuit

## Declaration of Conformity

Visit [rok.auto/certifications](http://rok.auto/certifications) for Declaration of Conformity, certificates, and other certification details.

- UL Listed Industrial Control Equipment, Certified for US and Canada
- CE Marked for all applicable directives
- UKCA Marked for all applicable regulations
- RCM Marked
- TÜV Certified for Functional Safety up to SIL 3 Category 4 for use in safety applications up to and including SIL 3. Also in accordance with IEC 61508 and EN 62061, Performance Level e and Category 4 in accordance with ISO 13849-1, both for guard position monitoring and for guard locking according to ISO 14119.
- FCC Notice (for U.S. Customers)

This device complies with Part 15 of the FCC Rules. Operation is subject to the following conditions:

- This device must not cause harmful interference, and
- This device must accept any interference received, including interference that can cause undesired operation.

Changes and Modifications that are not expressly approved by Rockwell Automation can void your authority to operate this equipment under Federal Communications Commissions rules.

- This device complies with Industry Canada license-exempt RSS standard(s). Operation is subject to the following two conditions: (1) this device may not cause interference, and (2) this device must accept any interference, including interference that may cause undesired operation of the device.

Le présent appareil est conforme aux CNR d'Industrie Canada applicables aux appareils radio exempts de licence. L'exploitation est autorisée aux deux conditions suivantes : (1) l'appareil ne doit pas produire de brouillage, et (2) l'utilisateur de l'appareil doit accepter tout brouillage radioélectrique subi, même si le brouillage est susceptible d'en compromettre le fonctionnement.

## **CE Conformity**

This product bears the CE marking and is approved for installation within the European Union and EEA regions. It has been designed and tested to meet the Machine Safety and EMC Directives.

## **UKCA Conformity**

Rockwell Automation declares that the products that are shown in this document are in compliance with UK Electromagnetic Compatibility regulations (2016 No.1091), Supply of Machinery Safety regulations (2008 No. 1597) and have Third-party Approval.

**Notes:**

## Numerics

### 1732 ArmorBlock

wiring 34

### 1734 POINT Guard I/O

wiring 30

## A

### actuator

clearance 12  
mount 9

### additional target

learn 18

### allowable approach direction 9

### application

example 23

### approach direction

allowable 9

### audience 5

### auxiliary 24

output 16

## C

### catalog number explanation 7

### CE conformity 51

### clearance

actuator 12

### close coupled 9

### commission 17

error 19  
preparation 17  
wiring 17

### conformity

CE 51  
UKCA 51

### connection 15

### consideration

installation 9

### content

packaging 8

### cover

manual override 11

### CR30 relay

wiring 28

## D

### DG relay

wiring 27

### DI relay

wiring 26

### dimensions 13

### direction

allowable approach 9

## E

### EMD relay

wiring 26

### error

commission 19

### example

application 23  
wiring 23

## F

### first target

learn 18

### first time

power-up 17

### flowchart

troubleshooting 40

### functional test 21

## G

### GLP relay

wiring 23

### GLT relay

wiring 24

### guide

reposition 11

## H

### holding force 12, 13

## I

### input

OSSD 15

### installation 9

consideration 9

## L

### learn

additional target 18  
first target 18

### lock command 16

### locking bolt

steel 12

## M

### manual override cover 11

### manual release 10

### mount

actuator/target 9

**O****operating radius**

minimum 10

**OSSD**

input 15

output 15

**output**

auxiliary 16

OSSD 15

**overview** 7**P****packaging content** 8**pair proximity** 11**power-up**

first time 17

self-check 19

**preparation**

commission 17

**purpose** 5**R****radius**

operating 10

**rating**

safety 49

**release**

manual 10

**reposition**

guide 11

**S****safety rating** 49**self-check**

power-up 19

**steel locking bolt** 12**T****target**

learn additional 18

learn first 18

mount 9

**terminology** 6**test**

functional 21

procedure 21

**troubleshooting** 39

flowchart 40

**U****UKCA conformity** 51**W****wiring** 15

commission 17

example 23

to 1732 ArmorBlock 34

to 1734 POINT Guard I/O 30

to CR30 relay 28

to DG relay 27

to DI and EMD relay 26

to GLP relay 23

to GLT relay 24



# Rockwell Automation Support

Use these resources to access support information.

<b>Technical Support Center</b>	Find help with how-to videos, FAQs, chat, user forums, Knowledgebase, and product notification updates.	<a href="http://rok.auto/support">rok.auto/support</a>
<b>Local Technical Support Phone Numbers</b>	Locate the telephone number for your country.	<a href="http://rok.auto/phonesupport">rok.auto/phonesupport</a>
<b>Technical Documentation Center</b>	Quickly access and download technical specifications, installation instructions, and user manuals.	<a href="http://rok.auto/techdocs">rok.auto/techdocs</a>
<b>Literature Library</b>	Find installation instructions, manuals, brochures, and technical data publications.	<a href="http://rok.auto/literature">rok.auto/literature</a>
<b>Product Compatibility and Download Center (PCDC)</b>	Download firmware, associated files (such as AOP, EDS, and DTM), and access product release notes.	<a href="http://rok.auto/pcdc">rok.auto/pcdc</a>

## Documentation Feedback

Your comments help us serve your documentation needs better. If you have any suggestions on how to improve our content, complete the form at [rok.auto/docfeedback](http://rok.auto/docfeedback).

## Waste Electrical and Electronic Equipment (WEEE)



At the end of life, this equipment should be collected separately from any unsorted municipal waste.





Rockwell Automation maintains current product environmental compliance information on its website at [rok.auto/pec](http://rok.auto/pec).

Allen-Bradley, ArmorBlock, Connected Components Workbench, expanding human possibility, GuardLink, GuardLogix, Guardmaster, POINT Guard I/O, PowerFlex, Rockwell Automation, SensaGuard, and Studio 5000 are trademarks of Rockwell Automation, Inc.

EtherNet/IP is a trademark of ODVA, Inc.

Trademarks not belonging to Rockwell Automation are property of their respective companies.

Rockwell Otomasyon Ticaret A.Ş. Kar Plaza İş Merkezi E Blok Kat:6 34752, İçerenköy, İstanbul, Tel: +90 (216) 5698400 EEE Yönetmeliğine Uygundur

Connect with us.    

**rockwellautomation.com** — expanding **human possibility**<sup>®</sup>

AMERICAS: Rockwell Automation, 1201 South Second Street, Milwaukee, WI 53204-2496 USA, Tel: (1) 414.382.2000

EUROPE/MIDDLE EAST/AFRICA: Rockwell Automation NV, Pegasus Park, De Kleetlaan 12a, 1831 Diegem, Belgium, Tel: (32) 2663 0600

ASIA PACIFIC: Rockwell Automation SEA Pte Ltd, 2 Corporation Road, #04-05, Main Lobby, Corporation Place, Singapore 618494, Tel: (65) 6510 6608

UNITED KINGDOM: Rockwell Automation Ltd., Pitfield, Kiln Farm, Milton Keynes, MK11 3DR, United Kingdom, Tel: (44)(1908) 838-800

Publication 440G-UM002E-EN-P - April 2024

Supersedes Publication 440G-UM002D-EN-P - August 2023

Copyright © 2024 Rockwell Automation, Inc. All rights reserved. Printed in the U.S.A.