

PCE-3B03A-00 Backplane: 3 Slot PICMG1.3 Half-size BP, 1 PCIe x16, 1 PCIe x4 Startup Manual

Packing List

Before you begin installing your card, please make sure that the following items have been shipped:

- PCE-3B03A-00 User Manual 1st.ED p/n: 20063B0300
- 2 years quality warranty card p/n: 2190000902

If any PCE-3B03A-00 of these items are missing or damaged, please contact your distributor or sales representative immediately.

Specifications

Standard Functions

- **PICMG 1.3 slots:** PCE-3B03A-00 supports PICMG1.3 half-sized SHB
- **PCIe slots:** PCE-3B03A-00 supports one PCIe x16, one PCIe x4

Mechanical and Environmental

- **Dimensions:** 173 x 86.3 mm
- **Power supply voltage:** +12 V, +5 V, -12 V, +3.3 V +5VSBY
- **Power requirements:** Refer to the CPU board, add-on card & peripherals
- **Operating temperature:** 0 ~ 60° C
- **Weight:** 0.104 kg (weight of board)

For more information on this and other Advantech products, please visit our website at:

<http://www.advantech.com>

<http://www.advantech.com/eplatform>

For technical support and service, please visit our support website at:

<http://www.advantech.com/support>

This manual is for the PCE-3B03A-00 series Rev. A1.

Part No. 20063B0300
Printed in China

1st Edition,
Dec. 2012

Connectors and Jumpers

The backplane has a number of connectors and jumpers that allow you to configure your system to suit your application. The table below lists the function of each of the jumpers and connectors:

Connectors	
Label	Function
SHBA1~SHBB1	PICMG1.3 CPU board slot
PCIEX16_1	PCIe x16 slot
PCIEX4_1	PCIe x4 slot
EATXPWR1	ATX2.0 24-pin power connector
ATX12V1	ATX 12 V 4-pin power connector
FAN1	FAN connector
FAN2	FAN connector
FAN3	Reserved
SMBUS1	SMBus connector for chassis monitor
JFP1	Power and reset button connector

Jumpers	
Label	Function
PSON1	ATX / AT mode selection
JFAN_CTRL1	System smart fan selection

ATX12V1	
Pin	Name
1	GND
2	GND
3	12 V
4	12 V

EATXPWR1	
Pin	Name
1	3.3 V
2	3.3 V
3	GND
4	5 V
5	GND
6	5 V
7	GND
8	Power OK
9	5 V SB
10	12 V
11	12 V
12	3.3 V
13	3.3 V
14	-12 V
15	GND
16	PSON#
17	GND
18	GND
19	GND
20	-5 V
21	5 V
22	5 V
23	5 V
24	GND

Connectors and Jumpers

FAN1 - FAN3

Pin	Name
1	GND
2	+12 V_FAN
3	NC

SMBUS1

Pin	Name
1	5 V
2	C-SMBBUS
3	C-SMBDAT
4	GND

JFP1

Pin	Name
1	PWRBTN
2	GND
3	RESET
4	GND

PSON1: ATX/AT Mode Selection

Jumper Setting	Function
1-2	AT mode
2-3 (Default)	ATX mode

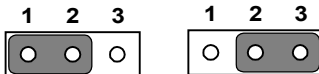

JFAN_CTRL1: System smart fan selection

Jumper Setting	Function
1-2	System smart fan
2-3 (Default)	System full speed fan

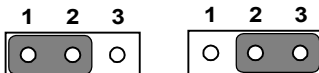

Locating Connectors and Jumpers

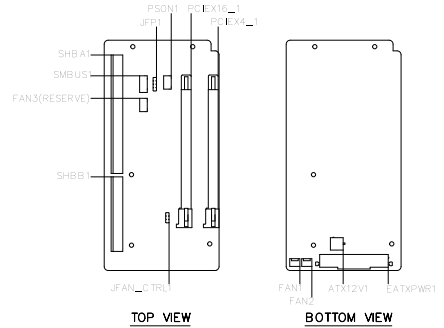

Figure1: Locating Connectors and Jumpers

Board Diagram

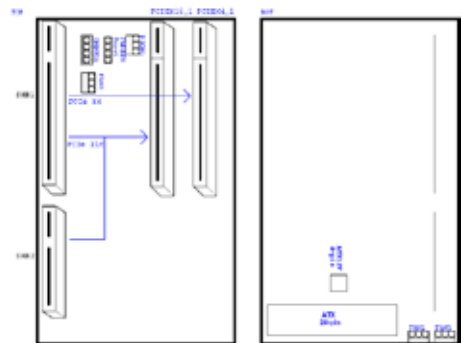

Figure2: PCE-3B03A-00 Board Diagram

Board Dimensions

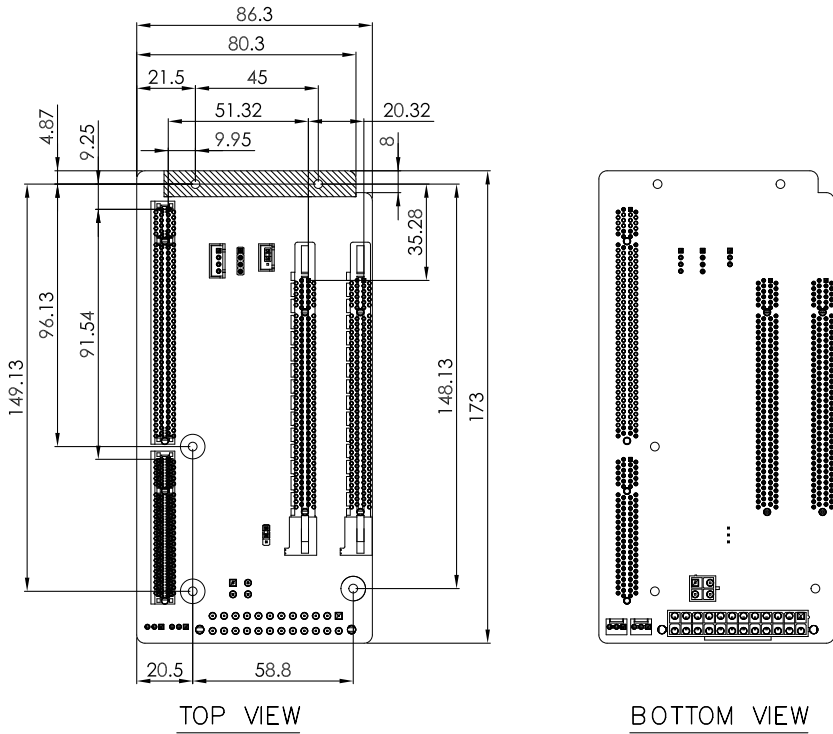

Figure 3: Mechanical Drawing