

PCE-3B06-00 Backplane: 6 Slot PICMG1.3 Half-size BP, 1 x PCIe x16, 4 x PCIe x1 Startup Manual

Packing List

Before you begin installing your card, please make sure that the following items have been shipped:

- PCE-3B06-00 user manual 2nd ed. p/n: 20023B0611
- 2-year quality warranty card p/n: 2190000902

If any PCE-3B06-00 of these items are missing or damaged, please contact your distributor or sales representative immediately.

Specifications

Standard Functions

- **PICMG 1.3 slots:** PCE-3B06-00 supports PICMG1.3 half-sized SHB
- **PCIe slots:** PCE-3B06-00 supports one PCIe x16 slot, four PCIe x1 slot

Mechanical and Environmental

- **Dimensions:** 176 X 142.17 mm
- **Power supply voltage:** +12 V, +5 V, -12 V, +3.3 V +5VSBY
- **Power requirements:** Refer to the CPU Board, add-on card & peripherals
- **Operating temperature:** 0 ~ 60 °C
- **Weight:** 0.2 kg (weight of board)

For more information on this and other Advantech products, please visit our website at:

<http://www.advantech.com>

<http://www.advantech.com/eplatform>

For technical support and service, please visit our support website at:

<http://www.advantech.com/support>

This manual is for the PCE-3B06-00 series Rev. A1.

Part No. 20023B0611
Printed in China

2nd Edition,
July 2013

Connectors and Jumpers

The backplane has a number of connectors and jumpers that allow you to configure your system to suit your application. The table below lists the function of each of the jumpers and connectors:

Connectors	
Label	Function
SHBA1~SHBB1	PICMG1.3 CPU board slot
PCIEX16_1	PCIe x16 slot
PCIEX1_1, PCIEX1_2, PCIEX1_3, PCIEX1_4	PCIe x1 slot
EATXPWR1	ATX2.0 24-pin power connector
ATX12V1	ATX 12V 4-pin power connector
VOLT1	Alarm board / CMM power connector
FAN1	FAN connector
FAN2	FAN connector
FAN3	FAN connector
SMBUS1	SMBus connector for chassis monitor
JFP1	Power and reset button connector

Jumpers	
Label	Function
PSON1	ATX / AT mode selection
JFAN_CTRL1	System smart fan control

EATXPWR1	
Pin	Name
1	3.3 V
2	3.3 V
3	GND
4	5 V
5	GND
6	5 V
7	GND
8	Power OK
9	5 V SBY
10	12 V

11	12 V
12	3.3 V
13	3.3 V
14	-12 V
15	GND
16	PSON#
17	GND
18	GND
19	GND
20	-5 V
21	5 V
22	5 V
23	5 V
24	GND

ATX12V1	
Pin	Name
1	GND
2	GND
3	12 V
4	12 V

VOLT1	
Pin	Name
1	5 V SBY
2	GND
3	GND
4	-5 V
5	5 V
6	3.3 V
7	-12 V
8	12 V

FAN1 - FAN3	
Pin	Name
1	GND
2	12 v
3	FANIO1~FANIO3

SMBUS1	
Pin	Name
1	5 V
2	C-SMBCLK
3	C-SMBDAT
4	GND

JFP1	
Pin	Name
1	PWRBTN
2	GND
3	RESET
4	GND

PSON1: ATX/AT Mode Selection	
Jumper Setting	Function
1-2	AT mode
2-3 (Default)	ATX mode



JFAN_CTRL1: System Smart Fan Control	
Jumper Setting	Function
1-2 (Default)	Smart fan
2-3	Full speed fan

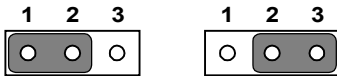

Locating Connectors and Jumpers

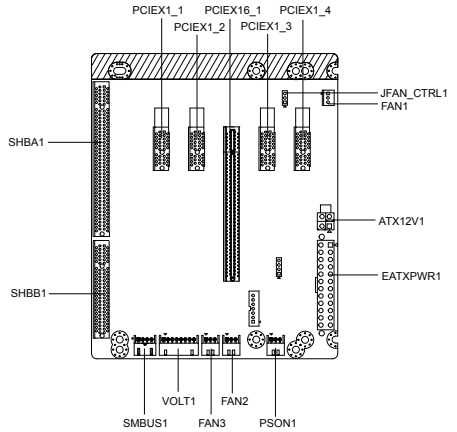

Figure 1: Locating Connectors and Jumpers

Board Dimensions

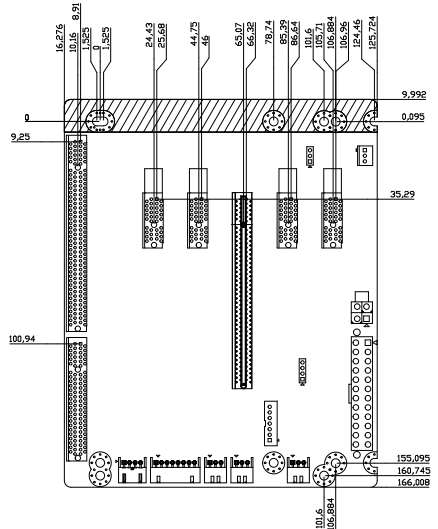

Figure 2: Mechanical Drawing

Board Diagram

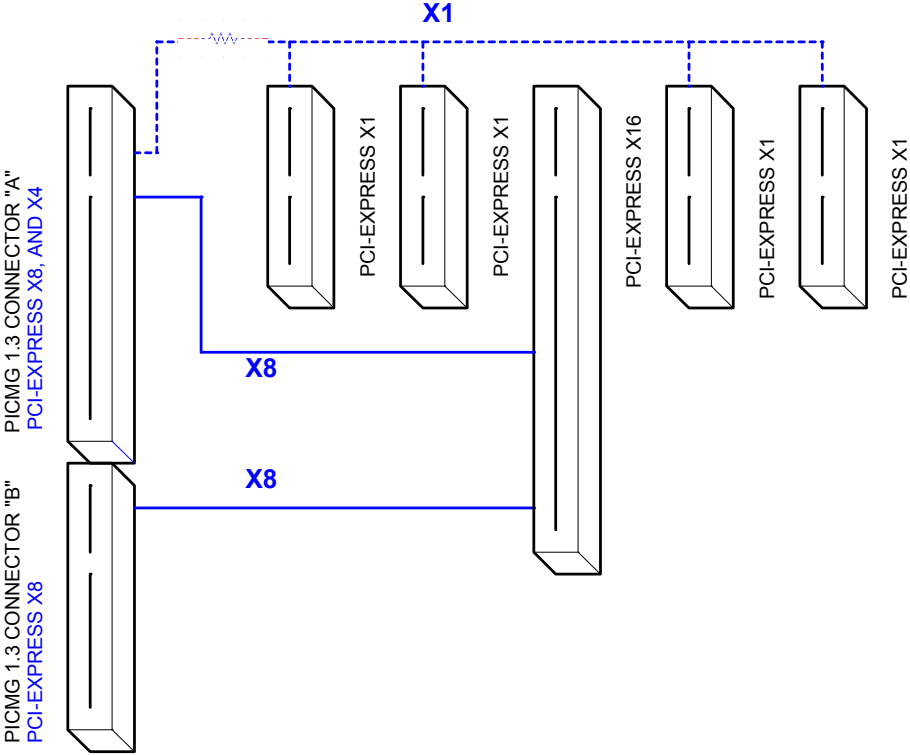

Figure3: PCE-3B06-00 Board Diagram