

DLT-V7212 P+

Rugged X86-Based Vehicle-Mounted Terminal



Features

- 12.1" color TFT display
- Intel® Atom™ E3845 quad-core processor
- Projective capacitive (P-CAP) touchscreen with multi-touch control
- IP66 rating for water and dust resistance
- 5M3 certification for shock and vibration tolerance
- Impact tolerant, abrasion-resistant touchscreen with IK08 classification
- Wide operating temperature range (-30 ~ 50 °C/-22 ~ 122 °F) for extreme environments
- Optional uninterruptible power supply via backup battery (supports up to 20 minutes operation)
- Optional smart sensors for extended functions e.g. screen blanking for driving safety

Introduction

DLT-V7212 P+ is a rugged vehicle-mounted terminal designed for logistics applications and to provide maximum system uptime. The compact thin bezel design allows it to fit into the smallest vehicle cabin. DLT-V7212 P+ increases driving safety, as its compact design is reducing the visual field restrictions to a minimum. Powered by an Intel® Atom™ E3845 quad-core, 1.91 GHz, processor with 4 GB RAM, DLT-V7212 P+ supports a wide operating temperature range (-30 ~ 50 °C/-22 ~ 122 °F) to withstand operation in extreme industrial environments (from hot and humid, to dry freezer environments). The integrated Advantech low-profile antenna offers excellent transmission capabilities in a compact form factor. The PCT touchscreen ensures easy input and supports gloved operation.

Specifications

System	CPU	Intel® Atom™ E3845 quad-core, 1.91 GHz, 4 GB RAM
	Memory	8GB - 256GB CFast
Dimensions		297 x 266 x 77 mm (11.69 x 10.47 x 3.03 in)
Weight		3.7 kg (8 lb) without battery pack/antenna/accessories
Housing		Completely sealed, fanless design made of coated aluminum
Display		12.1" XGA color TFT with 1024 x 768 resolution and 600 cd/m ² brightness
Touchscreen	Type	Projective capacitive (P-CAP) touchscreen, optical bonded with multi-touch control
Control Buttons	Front Panel	3 x control buttons
Software	Operating System	Windows 10 IoT Enterprise, Windows 7 Pro, Windows Embedded Standard 7, Debian-based Linux, IGEL Linux
	Emulations (Third-Party)	VT100, VT220, IBM 5250, TN 3270, Citrix Client®, Freefloat Access One
Communication	WLAN	WLAN IEEE 802.11 a/b/g/n/ac (optional)
	WWAN	WWAN (LTE, UMTS, HSPA+, GSM, GPRS, EDGE) (optional)
	LAN	Ethernet 10/100/1000 Mbit/s
	WPAN	Bluetooth 4.2 (optional)
Interfaces	Serial	2 x RS-232, COM1 with switchable 5 V _{DC} /RI
	USB	4 x USB 2.0 (Hi-Speed™) bootable, 1 x service USB 3.0 (Super-Speed™)
	External Antennas	1 x RSMA for WLAN, 1 x SMA for WWAN (optional)
Sensors		Accelerometer, Gyro (optional)
Audio		1 x integrated speaker
Power Supply		12/24/48 V _{DC} nominally
		Automatic Power On/Off function via vehicle ignition with optional UPS (20 minutes typical); battery life may vary according to load
Environmental	IP Rating	IP66 rating for the entire system
	Operating Temperature	-30 ~ 50 °C (-22 ~ 122 °F)
	Relative Humidity	10 to 90% at 40 °C (104 °F), non-condensing
	Shock/Vibration	5M3 (EN 60721-3-5) and MIL-STD 810F (US highway truck vibration exposure)
Certifications	Touchscreen Durability	IK 08
		CE Immunity Class A, Emission Class B/FCC Class B (for EU and USA), CCC (for China)

Dimensions

Unit: mm

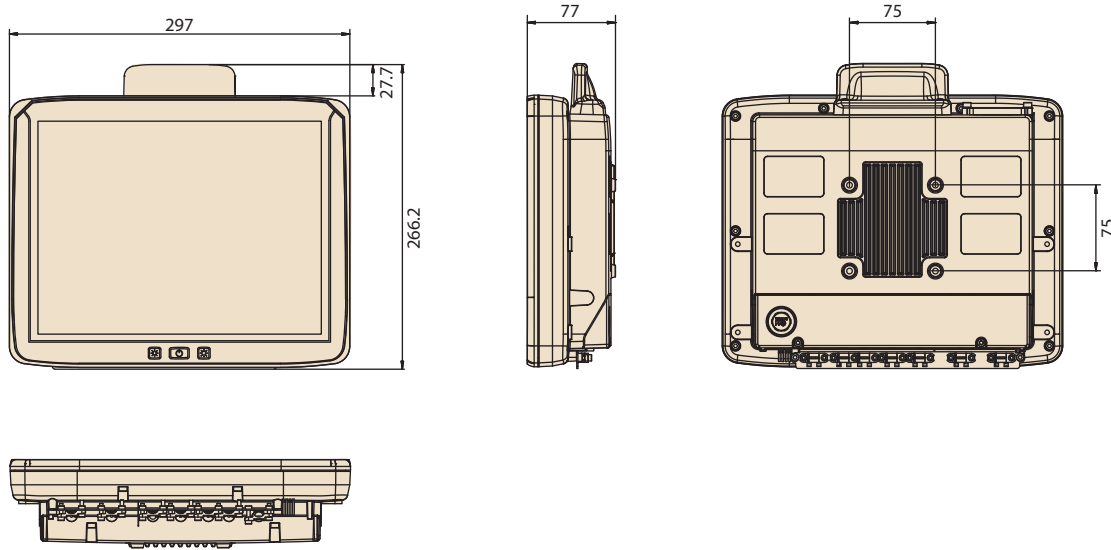

Optional Accessories

Part Number	Description
DL-MTK009	Mounting bracket mobile
DL-MTRM004	RAM-Mount Set, one arm, arm length 130mm
DL-MTRM003	RAM-Mount Set, one arm, arm length 215mm
DL-MTRM001	RAM-Mount Set, two arms, arm length 150mm

Further configurations on request!

I/O Connectors

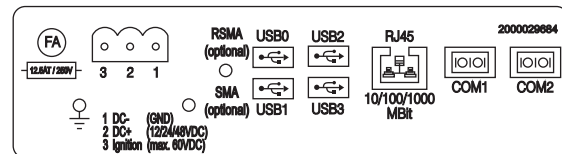

Mount Kit Options

RAM-Mount Set (one arm)

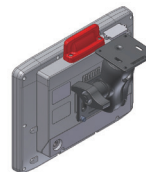

RAM-Mount Set (two arms)

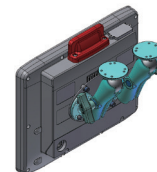

Mobile Mounting Bracket

