

DSCA36

Potentiometer Input Signal Conditioners



Description

Each DSCA36 potentiometer input module provides a single channel of potentiometer input which is filtered, isolated, amplified, and converted to a high level voltage output. Signal filtering is accomplished with a five-pole filter which provides 85dB of normal-mode-rejection at 60Hz and 80dB at 50Hz. An anti-aliasing pole is located on the field side of the isolation barrier, and the other four poles are on the system side. After the initial field-side filtering, the input signal is chopped by a proprietary chopper circuit. Isolation is provided by transformer coupling, again using a proprietary technique to suppress transmission of common mode spikes or surges.

Potentiometer excitation is provided from the module using a precision current source. Lead compensation is achieved by matching two current paths which cancels the effects of lead resistance. The excitation current is small (approx. 0.25mA) which minimizes self-heating of the sensor.

Module output is either voltage or current. For current output models a dedicated loop supply is provided at terminal 3 (+OUT) with loop return located at terminal 4 (-OUT). The system-side load may be either floating or grounded.

Special input circuits provide protection against accidental connection of power-line voltages up to 240VAC and against transient events as defined by ANSI/IEEE C37.90.1. Protection circuits are also present on the signal output and power input terminals to guard against transient events and power reversal. Signal and power lines are secured to the module using screw terminals which are in pluggable terminal blocks for ease of system assembly and reconfiguration.

The modules have excellent stability over time and do not require recalibration, however, zero and span settings are adjustable up to $\pm 5\%$ to accommodate situations where fine-tuning is desired. The adjustments are made using potentiometers located under the front panel label and are non-interactive for ease of use.

► Features

- Interfaces to Potentiometers up to 10k Ω
- Industry Standard Output of Either 0-10V, 0-20mA, or 4-20mA
- 1500Vrms Transformer Isolation
- ANSI/IEEE C37.90.1 Transient Protection
- Input Protected to 240VAC Continuous
- True 3-Way Isolation
- Wide Range of Supply Voltage
- 160dB CMR
- 85dB NMR at 60Hz, 80dB at 50Hz
- $\pm 0.03\%$ Accuracy
- $\pm 0.01\%$ Linearity
- Easily Mounts on Standard DIN Rail
- C-UL-US Listed
- CE and ATEX Compliant

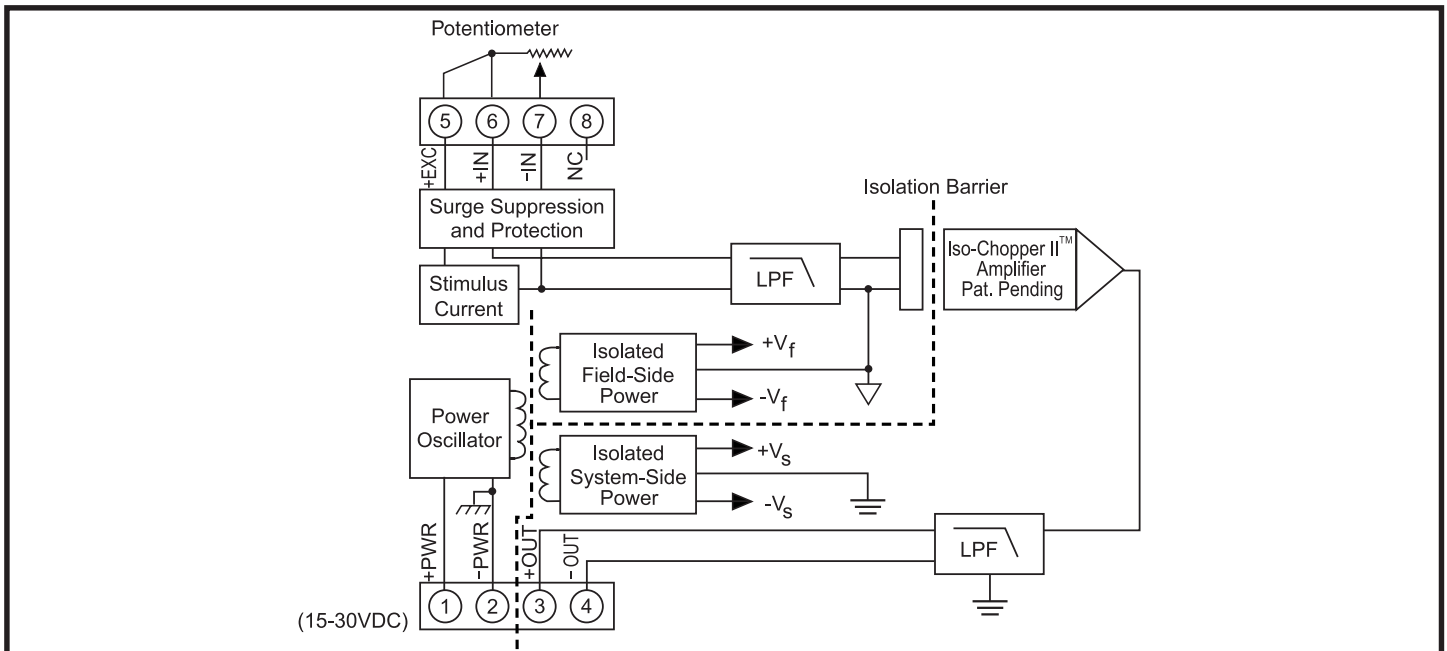

Figure 1: DSCA36 Block Diagram

Specifications Typical at $T_A = +25^\circ\text{C}$ and +24V supply voltage

Module	DSCA36
Input Range Limits	0Ω to 10kΩ
Input Protection	
Continuous	240Vrms max
Transient	ANSI/IEEE C37.90.1
Sensor Excitation Current	260μA; 100Ω, 500Ω, 1kΩ Sensor 65μA; 10kΩ Sensor
Lead Resistance Effect	$\pm 0.01\Omega/\Omega$; 100Ω, 500Ω, 1kΩ Sensor $\pm 0.02\Omega/\Omega$; 10kΩ Sensor
Output Range	See Ordering Information
Load Resistance (I_{OUT})	600Ω max
Current Limit	8mA (V_{OUT}), 30mA (I_{OUT})
Output Protection	
Short to Ground	Continuous
Transient	ANSI/IEEE C37.90.1
CMV, Input to Output, Input to Power	
Continuous	1500Vrms max
Transient	ANSI/IEEE C37.90.1
CMV, Output to Power	
Continuous	50VDC max
CMR (50Hz or 60Hz)	160dB
Accuracy ⁽¹⁾	$\pm 0.03\%$
Conformity	$\pm 0.01\%$
Adjustability	$\pm 5\%$ Zero and Span
Stability	
Input Offset	$\pm 0.004\Omega/^\circ\text{C}$; 100Ω, 500Ω, 1kΩ Sensor $\pm 0.01\Omega/^\circ\text{C}$; 10kΩ Sensor
Output Offset	$\pm 6\text{ppm}/^\circ\text{C}$ (V_{OUT}), $\pm 20\text{ppm}/^\circ\text{C}$ (I_{OUT})
Gain	$\pm 60\text{ppm}/^\circ\text{C}$
Output Noise, 100kHz Bandwidth	250μVrms (V_{OUT}), 1μArms (I_{OUT})
Bandwidth, -3dB	3Hz
NMR	85dB at 60Hz, 80dB at 50Hz
Response Time, 90% Span	250ms
Open Input Response	
'+' Lead	Upscale
'-' Lead	Non-deterministic
'x' Lead	Downscale
Power Supply	
Voltage	15 to 30VDC
Current	25mA (V_{OUT}), 55mA (I_{OUT})
Sensitivity	$\pm 0.0001\%/%$
Protection	
Reverse Polarity	Continuous
Transient	ANSI/IEEE C37.90.1
Environmental	
Operating Temp. Range	-40°C to +80°C
ATEX Group II, Category 3	-20°C to +40°C
Storage Temp. Range	-40°C to +80°C
Relative Humidity	0 to 95% Noncondensing
Emissions EN61000-6-4	ISM, Group 1
Radiated, Conducted	Class A
Immunity EN61000-6-2	ISM, Group 1
RF	Performance A $\pm 0.05\%$ Span Error
ESD, EFT, Surge, Voltage Dips	Performance B
Mechanical Dimensions	2.95" x 0.89" x 4.13"
(h)(w)(d)	(75mm x 22.5mm x 105mm)
Mounting	DIN EN 50022 -35x7.5 or -35x15 rail

NOTES:

(1) Includes nonlinearity, hysteresis and repeatability.

Installation Notes:

- 1.) This Equipment is Suitable for Use in Class I, Division 2, Groups A, B, C, D, or Non-Hazardous Locations Only.
- 2.) Warning - Explosion Hazard - Substitution of Components May Impair Suitability for Class I, Division 2.
- 3.) Warning - Explosion Hazard - Do Not Disconnect Equipment Unless Power Has Been Switched Off or The Area is Known to be Non-Hazardous.

Ordering Information

Model	Input Range	Output Range†
DSCA36-01	0 to 100Ω	2, 3, 4
DSCA36-02	0 to 500Ω	2, 3, 4
DSCA36-03	0 to 1kΩ	2, 3, 4
DSCA36-04	0 to 10kΩ	2, 3, 4

†Output Ranges Available

Output Range	Part No. Suffix	Example
1. -10V to +10V	NONE	NA
2. 0V to +10V	NONE	DSCA36-01
3. 4 to 20mA	C	DSCA36-01C
4. 0 to 20mA	E	DSCA36-01E