

DSCA38

Strain Gage Input Signal Conditioners



Description

Each DSCA38 strain gage input module provides a single channel of strain gage input which is filtered, isolated, amplified, and converted to a high level voltage output. Signal filtering is accomplished with a five-pole filter which is optimized for step response. An anti-aliasing pole is located on the field side of the isolation barrier, and the other four poles are on the system side. After the initial field-side filtering, the input signal is chopped by a proprietary chopper circuit. Isolation is provided by transformer coupling, again using a proprietary technique to suppress transmission of common mode spikes or surges.

The DSCA38 can interface to transducers with a nominal resistance of 100Ω to 10kΩ. Strain gage excitation is provided from the module by a stable 10V or 3.333V source. This source is fully isolated, allowing the amplifier inputs to operate over the full range of the excitation voltage. This feature enables the module to be interfaced to other sensors requiring excitation.

Module output is either voltage or current. For current output models a dedicated loop supply is provided at terminal 3 (+OUT) with loop return located at terminal 4 (-OUT). The system-side load may be either floating or grounded.

Special input circuits provide signal input and excitation protection against accidental connection of power-line voltages up to 240VAC and against transient events as defined by ANSI/IEEE C37.90.1. Protection circuits are also present on the signal output and power input terminals to guard against transient events and power reversal. Signal and power lines are secured to the module using screw terminals which are in pluggable terminal blocks for ease of system assembly and reconfiguration.

The modules have excellent stability over time and do not require recalibration, however, zero and span settings are adjustable up to ±5% to accommodate

► Features

- Interfaces to 100Ω through 10kΩ Strain Gages
- Industry Standard Output of either ±10V, 0-20mA, or 4-20mA
- 1500Vrms Transformer Isolation
- ANSI/IEEE C37.90.1 Transient Protection
- Input Protected to 240VAC Continuous
- True 3-Way Isolation
- Wide Range of Supply Voltage
- 100dB CMR
- Fully Isolated Excitation Supply
- ±0.03% Accuracy
- ±0.01% Linearity
- Easily Mounts on Standard DIN Rail
- C-UL-US Listed
- CE and ATEX Compliant

situations where fine-tuning is desired. The zero adjustment can be used to offset bridge imbalances. The adjustments are made using potentiometers located under the front panel label and are non-interactive for ease of use.

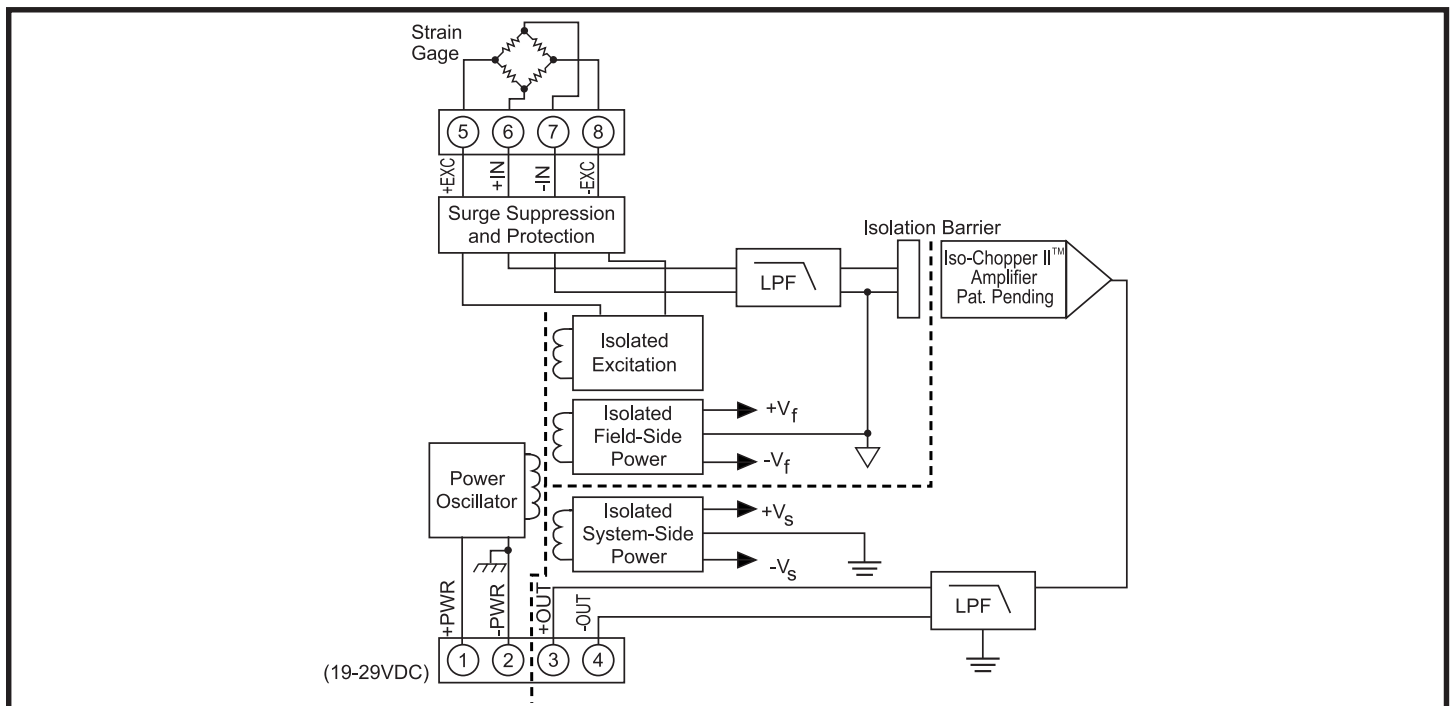

Figure 1: DSCA38 Block Diagram

Specifications Typical at $T_A = +25^\circ\text{C}$ and +24V supply voltage

Module	DSCA38
Input Range	$\pm 10\text{mV}$ to $\pm 100\text{mV}$
Input Bias Current	$\pm 0.5\text{nA}$
Input Resistance	
Normal	50M Ω
Power Off	65k Ω
Overload	65k Ω
Signal Input Protection	
Continuous	240Vrms max (Full Bridge) 120Vrms max (Half Bridge)
Transient	ANSI/IEEE C37.90.1
Excitation	
Output	10V $\pm 0.03\%$ or 3.33V $\pm 0.03\%$
Load Resistance (10V)	300 Ω to 10k Ω
Load Resistance (3.33V)	100 Ω to 10k Ω
Load Regulation	$\pm 5\text{ppm}/\text{mA}$
Stability	$\pm 15\text{ppm}/^\circ\text{C}$
Protection	
Continuous	240Vrms max
Transient	ANSI/IEEE C37.90.1
Output Range	See Ordering Information
Load Resistance (I_{OUT})	600 Ω max
Current Limit	8mA (V_{OUT}), 30mA (I_{OUT})
Output Protection	
Short to Ground	Continuous
Transient	ANSI/IEEE C37.90.1
CMV, Input to Output, Input to Power	
Continuous	1500Vrms max
Transient	ANSI/IEEE C37.90.1
CMV, Output to Power	
Continuous	50VDC max
CMR (50Hz or 60Hz)	100dB
Accuracy ⁽¹⁾	$\pm 0.03\%$ Span
Nonlinearity	$\pm 0.01\%$ Span
Adjustability	$\pm 5\%$ Zero and Span
Stability	
Input Offset	$\pm 1\mu\text{V}/^\circ\text{C}$
Output Offset	$\pm 6\text{ppm}/^\circ\text{C}$ (V_{OUT}), $\pm 20\text{ppm}/^\circ\text{C}$ (I_{OUT})
Gain	$\pm 55\text{ppm}/^\circ\text{C}$
Output Noise, 100kHz Bandwidth	750 μVrms (V_{OUT}), 3 μArms (I_{OUT})
Bandwidth, -3dB	3kHz
NMR	100dB/Decade Above 3kHz
Response Time, 90% Span	170 μs
Power Supply	
Voltage	19 to 29VDC
Current	60mA (V_{OUT}), 80mA (I_{OUT})
Sensitivity	$\pm 0.0002\%/%$
Protection	
Reverse Polarity	Continuous
Transient	ANSI/IEEE C37.90.1
Environmental	
Operating Temp. Range	-40°C to $+80^\circ\text{C}$
ATEX Group II, Category 3	-20°C to $+40^\circ\text{C}$
Storage Temp. Range	-40°C to $+80^\circ\text{C}$
Relative Humidity	0 to 95% Noncondensing
Emissions EN61000-6-4	ISM, Group 1
Radiated, Conducted	Class A
Immunity EN61000-6-2	ISM, Group 1
RF	Performance A $\pm 0.05\%$ Span Error
ESD, EFT, Surge, Voltage Dips	Performance B
Mechanical Dimensions	2.95" x 0.89" x 4.13"
(h)(w)(d)	(75mm x 22.5mm x 105mm)
Mounting	DIN EN 50022 -35x7.5 or -35x15 rail

NOTES:

(1) Includes nonlinearity, hysteresis and repeatability.

Ordering Information

Model	Input Bridge Type	Input Range	Excitation	Sens.	Output Range [†]
DSCA38-01	Full	-10mV to +10mV	+3.333V	3mV/V	1
DSCA38-02	Full	-30mV to +30mV	+10.0V	3mV/V	1
DSCA38-03	Half	-10mV to +10mV	+3.333V	3mV/V	1
DSCA38-04	Half	-30mV to +30mV	+10.0V	3mV/V	1
DSCA38-05	Full	-20mV to +20mV	+10.0V	2mV/V	1
DSCA38-06	Full	-33.3mV to +33.3mV	+3.333V	10mV/V	1
DSCA38-07	Full	-100mV to +100mV	+10.0V	10mV/V	1
DSCA38-08	Full	-10mV to +10mV	+3.333V	3mV/V	2, 3, 4
DSCA38-09	Full	-30mV to +30mV	+10.0V	3mV/V	2, 3, 4
DSCA38-10	Half	-10mV to +10mV	+3.333V	3mV/V	2, 3, 4
DSCA38-11	Half	-30mV to +30mV	+10.0V	3mV/V	2, 3, 4
DSCA38-12	Full	-20mV to +20mV	+10.0V	2mV/V	2, 3, 4
DSCA38-13	Full	-33.3mV to +33.3mV	+3.333V	10mV/V	2, 3, 4
DSCA38-14	Full	-100mV to +100mV	+10.0V	10mV/V	2, 3, 4
DSCA38-15	Full	0 to +10mV	+3.333V	3mV/V	2, 3, 4
DSCA38-16	Full	0 to +30mV	+10.0V	3mV/V	2, 3, 4
DSCA38-17	Half	0 to +10mV	+3.333V	3mV/V	2, 3, 4
DSCA38-18	Half	0 to +30mV	+10.0V	3mV/V	2, 3, 4
DSCA38-19	Full	0 to +20mV	+10.0V	2mV/V	2, 3, 4
DSCA38-20	Full	0 to +33.3mV	+3.333V	10mV/V	2, 3, 4
DSCA38-21	Full	0 to +100mV	+10.0V	10mV/V	2, 3, 4

†Output Ranges Available

Output Range	Part No. Suffix	Example
1. -10V to +10V	NONE	DSCA38-01
2. 0V to +10V	NONE	DSCA38-08
3. 4 to 20mA	C	DSCA38-08C
4. 0 to 20mA	E	DSCA38-08E

Installation Notes:

- 1.) This Equipment is Suitable for Use in Class I, Division 2, Groups A, B, C, D, or Non-Hazardous Locations Only.
- 2.) Warning - Explosion Hazard - Substitution of Components May Impair Suitability for Class I, Division 2.
- 3.) Warning - Explosion Hazard - Do Not Disconnect Equipment Unless Power Has Been Switched Off or The Area is Known to be Non-Hazardous.