

# DSCA45

## Frequency Input Signal Conditioners



### Description

Each DSCA45 frequency input module provides a single channel of frequency input which is isolated and converted to a standard analog voltage or current output (Figure 1).

The frequency input signal can be a TTL level or zero-crossing signal. Terminal 7 (-IN) on the field-side terminal block is the “common” or ground connection for input signals. A TTL signal is connected from terminal 6 (+IN) to terminal 7 (-IN), while a zero-crossing signal is connected from terminal 5 (+EXC) to terminal 7 (-IN). Input circuitry for each of the signal types has hysteresis built in. An input signal must cross entirely through the hysteresis region in order to trigger the threshold comparator.

A +5.1V excitation is available for use with magnetic pick-up or contact-closure type sensors. The excitation is available on terminal 8 (-EXC) with return at terminal 7 (-IN).

Module output is either voltage or current. For current output models a dedicated loop supply is provided at terminal 3 (+OUT) with loop return located at terminal 4 (-OUT). The system-side load may be either floating or grounded.

Special input circuits provide protection against accidental connection of power-line voltages up to 480VAC and against transient events as defined by ANSI/IEEE C37.90.1. Protection circuits are also present on the signal output and power input terminals to guard against transient events and power reversal. Signal and power lines are secured to the module using screw terminals which are pluggable terminal blocks for ease of system assembly and reconfiguration.

DSCA45 modules have excellent stability over time and do not require recalibration, however, both zero and span settings are adjustable to accom-

### ► Features

- Accepts Frequency Inputs of 0 to 100kHz
- Industry Standard Output of Either 0-10V, 0-20mA, or 4-20mA
- ±0.05% Factory Calibrated Accuracy
- Adjustable Zero (±5%) and Span (±5%)
- 1500Vrms Transformer Isolation
- Input Overload Protected to 240VAC Continuous
- ANSI/IEEE C37.90.1 Transient Protection
- Mounts on Standard DIN Rail
- C-UL-US Listed
- CE and ATEX Compliant

modate situations where fine tuning is desired. The adjustments are made using potentiometers located under the front panel label and are non-interactive for ease of use.

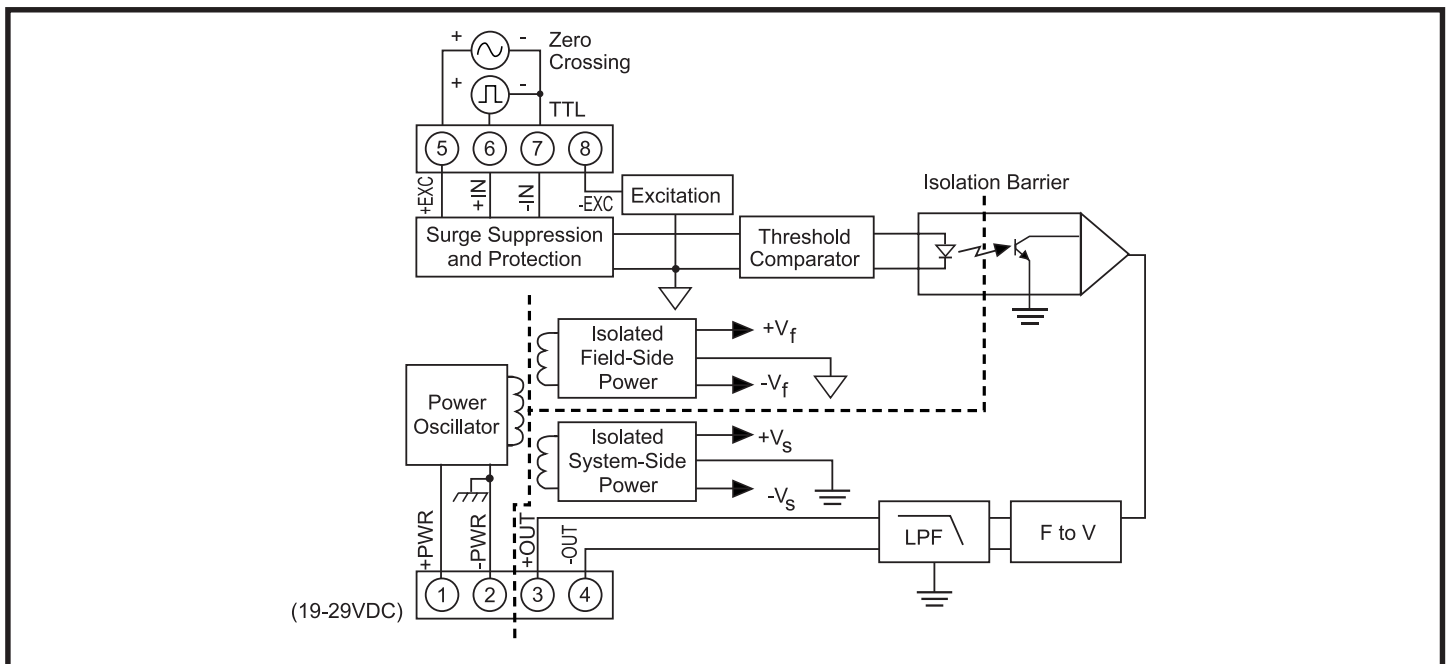

Figure 1: DSCA45 Block Diagram

**Specifications** Typical at  $T_A = +25^\circ\text{C}$  and +24V supply voltage

Module	DSCA45
Input	
Range	0 to 100kHz max
Threshold	Zero Crossing
Minimum Input	60mVp-p
Maximum Input	350Vp-p
Minimum Pulse Width	4 $\mu$ s
TTL Input Low	0.8V max
TTL Input High	2.4V min
Hysteresis	
Zero Crossing	40mV
TTL	1.5V
Resistance	100k $\Omega$
Protection	
Continuous	240Vrms max
Transient	ANSI/IEEE C37.90.1
Output Range	See Ordering Information
Adjustability	$\pm 5\%$ Zero & Span
Load Resistance ( $I_{OUT}$ )	600 $\Omega$ max.
Current Limit	8mA ( $V_{OUT}$ ), 30mA ( $I_{OUT}$ )
Output Protection	
Short to Ground	Continuous
Transient	ANSI/IEEE C37.90.1
Ripple	<0.20% Span at input >2% Span
Accuracy <sup>(1)</sup>	$\pm 0.05\%$ Span
vs. Temperature	$\pm 40\text{ppm}/^\circ\text{C}$ (Zero & Span)
Nonlinearity	$\pm 0.02\%$ Span
Isolation (Common Mode)	
Input to Output, Input to Power	
Continuous	1500Vrms max
Transient	ANSI/IEEE C37.90.1
Output to Power	
Continuous	50VDC max
Rejection (50-60Hz Common Mode)	120dB
Response Time (0 to 90%)	
DSCA45-01, -02, -03	310ms, 175ms, 50ms
DSCA45-04, -05, -06	30ms, 30ms, 15ms
DSCA45-07, -08	15ms, 1.5ms
Field Excitation	+5.1V $\pm 5\%$ at 8mA max
Power Supply	
Voltage	19 to 29VDC
Current	60mA ( $V_{OUT}$ ), 80mA ( $I_{OUT}$ )
Sensitivity	$\pm 0.0002\%/%$
Protection	
Reverse Polarity	Continuous
Transient	ANSI/IEEE C37.90.1
Environmental	
Operating & Storage Temp. Range	-40 $^\circ\text{C}$ to +80 $^\circ\text{C}$
ATEX Group II, Category 3	-20 $^\circ\text{C}$ to +40 $^\circ\text{C}$
Relative Humidity	0 to 95% noncondensing
Emissions EN61000-6-4	ISM, Group 1
Radiated, Conducted	Class A
Immunity EN61000-6-2	ISM, Group 1
RF	Performance A $\pm 0.05\%$ Span Error
ESD, EFT, Surge, Voltage Dips	Performance B
Mechanical Dimensions	2.95" x 0.89" x 4.13"
(h)(w)(d)	(75mm x 22.5mm x 105mm)
Mounting	DIN EN50022-35x7.5 or -35x15 rail

**NOTES:**

(1) Includes nonlinearity, hysteresis and repeatability.

**Ordering Information**

Model	Input Range	Output Range <sup>†</sup>
DSCA45-01	0-500Hz	2, 3, 4
DSCA45-02	0-1kHz	2, 3, 4
DSCA45-03	0-2.5kHz	2, 3, 4
DSCA45-04	0-5kHz	2, 3, 4
DSCA45-05	0-10kHz	2, 3, 4
DSCA45-06	0-25kHz	2, 3, 4
DSCA45-07	0-50kHz	2, 3, 4
DSCA45-08	0-100kHz	2, 3, 4

**<sup>†</sup>Output Ranges Available**

Output Range	Part No. Suffix	Example
1. -10V to +10V	NONE	N/A
2. 0V to +10V	NONE	DSCA45-01
3. 4 to 20mA	C	DSCA45-01C
4. 0 to 20mA	E	DSCA45-01E

**Installation Notes:**

- 1.) This Equipment is Suitable for Use in Class I, Division 2, Groups A, B, C, D, or Non-Hazardous Locations Only.
- 2.) Warning - Explosion Hazard - Substitution of Components May Impair Suitability for Class I, Division 2.
- 3.) Warning - Explosion Hazard - Do Not Disconnect Equipment Unless Power Has Been Switched Off or The Area is Known to be Non-Hazardous.