

DSCA47



Linearized Thermocouple Input Signal Conditioners

Description

Each DSCA47 thermocouple input module provides a single channel of thermocouple input which is filtered, isolated, amplified, linearized, and converted to a high level voltage output. Signal filtering is accomplished with a five-pole filter which provides 85dB of normal-mode-rejection at 60Hz and 80dB at 50Hz. An anti-aliasing pole is located on the field side of the isolation barrier, and the other four poles are on the system side. After the initial field-side filtering, the input signal is chopped by a proprietary chopper circuit. Isolation is provided by transformer coupling, again using a proprietary technique to suppress transmission of common mode spikes or surges.

The DSCA47 can interface to eight industry standard thermocouple types: J, K, T, E, R, S, B and N. Each module has cold junction compensation to correct for parasitic thermocouples formed by the thermocouple wire and input screw terminals on the module. Upscale open thermocouple detection is provided by internal circuitry. Downscale indication can be implemented by installing a 47MΩ, ±20% resistor between screw terminals 6 and 8 on the input terminal block.

Module output is either voltage or current. For current output models a dedicated loop supply is provided at terminal 3 (+OUT) with loop return located at terminal 4 (-OUT). The system-side load may be either floating or grounded.

Special input circuits provide protection against accidental connection of power-line voltages up to 240VAC and against transient events as defined by ANSI/IEEE C37.90.1. Protection circuits are also present on the signal output and power input terminals to guard against transient events and power reversal. Power lines are secured to the module using screw terminals which are in pluggable terminal blocks for ease of system assembly and reconfiguration.

The modules have excellent stability over time and do not require recalibration, however, zero and span settings are adjustable up to ±3% to accommodate

situations where fine-tuning is desired. The adjustments are made using potentiometers located under the front panel label and are non-interactive for ease of use.

► Features

- Interfaces to Types J, K, T, E, R, S, B, and N Thermocouples
- Linearizes Thermocouple Signal
- Industry Standard Output of either 0-10V, 0-20mA, or 4-20mA
- 1500Vrms Transformer Isolation
- ANSI/IEEE C37.90.1 Transient Protection
- Input Protected to 240VAC Continuous
- True 3-Way Isolation
- Wide Range of Supply Voltage
- 160dB CMR
- 85dB NMR at 60Hz, 80dB at 50Hz
- ±0.08% Accuracy
- Easily Mounts on Standard DIN Rail
- C-UL-US Listed
- CE and ATEX Compliant

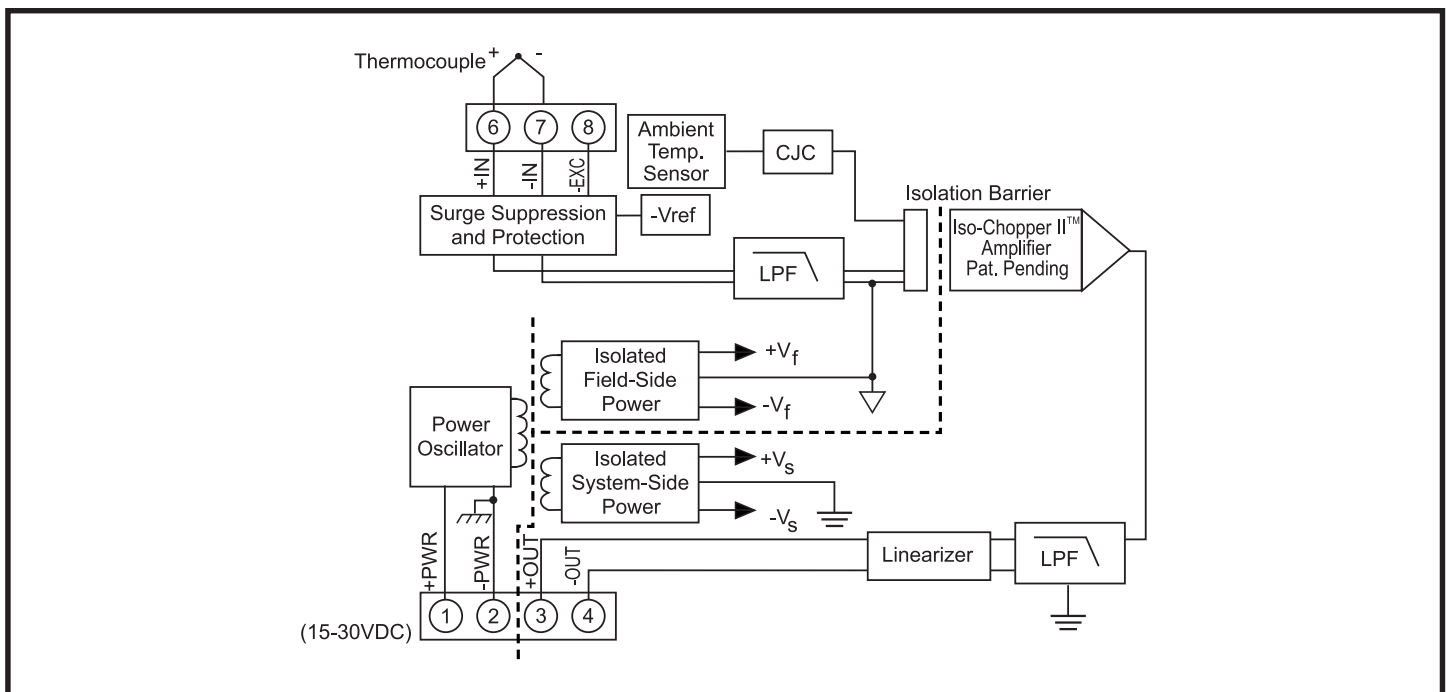

Figure 1: DSCA47 Block Diagram

Specifications Typical at $T_A = +25^\circ\text{C}$ and +24V supply voltage

Module	DSCA47
Input Range	Standard thermocouple temperature limits as per NIST monograph 175, ITS-90
Input Bias Current	-30nA
Input Resistance	
Normal	50M Ω
Power Off	65k Ω
Overload	65k Ω
Input Protection	
Continuous	240Vrms max
Transient	ANSI/IEEE C37.90.1
Cold Junction Compensation	
Accuracy, +5°C to +45°C	$\pm 0.5^\circ\text{C}$
Accuracy, -40°C to +85°C	$\pm 1.25^\circ\text{C}$
Output Range	See Ordering Information
Load Resistance (I_{OUT})	600 Ω
Current Limit	8mA (V_{OUT}), 30mA (I_{OUT})
Output Protection	
Short to Ground	Continuous
Transient	ANSI/IEEE C37.90.1
CMV, Input to Output, Input to Power	
Continuous	1500Vrms max
Transient	ANSI/IEEE C37.90.1
CMV, Output to Power	
Continuous	50VDC max
CMR (50Hz or 60Hz)	160dB
Accuracy	See Ordering Information Below
Adjustability	$\pm 3\%$ Zero and Span
Stability	
Input Offset	$\pm 0.5\mu\text{V}/^\circ\text{C}$
Output Offset	$\pm 6\text{ppm}/^\circ\text{C}$ (V_{OUT}), $\pm 20\text{ppm}/^\circ\text{C}$ (I_{OUT})
Gain	$\pm 40\text{ppm}/^\circ\text{C}$
Output Noise, 100kHz Bandwidth	250 μVrms (V_{OUT}), 1 μArms (I_{OUT})
Bandwidth, -3dB	3Hz
NMR	95dB at 60Hz, 85dB at 50Hz
Response Time, 90% Span	165ms
Open Input Response	Upscale
Open Input Detection Time	<5s
Power Supply	
Voltage	15 to 30VDC
Current	25mA (V_{OUT}), 55mA (I_{OUT})
Sensitivity	$\pm 0.0001\%/%$
Protection	
Reverse Polarity	Continuous
Transient	ANSI/IEEE C37.90.1
Environmental	
Operating Temp. Range	-40°C to +80°C
ATEX Group II, Category 3	-20°C to +40°C
Storage Temp. Range	-40°C to +80°C
Relative Humidity	0 to 95% Noncondensing
Emissions EN61000-6-4	ISM, Group 1
Radiated, Conducted	Class A
Immunity EN61000-6-2	ISM, Group 1
RF	Performance A $\pm 0.05\%$ Span Error
ESD, EFT, Surge, Voltage Dips	Performance B
Mechanical Dimensions	2.95" x 0.89" x 4.13"
(h)(w)(d)	(75mm x 22.5mm x 105mm)
Mounting	DIN EN 50022 -35x7.5 or -35x15 rail

NOTES:

(1) Includes conformity, hysteresis, repeatability and CJC error.

Installation Notes:

- 1.) This Equipment is Suitable for Use in Class I, Division 2, Groups A, B, C, D, or Non-Hazardous Locations Only.
- 2.) Warning - Explosion Hazard - Substitution of Components May Impair Suitability for Class I, Division 2.
- 3.) Warning - Explosion Hazard - Do Not Disconnect Equipment Unless Power Has Been Switched Off or The Area is Known to be Non-Hazardous.

Ordering Information

Model	TC Type [†]	Input Range	Output Range [‡]	Accuracy ¹
DSCA47J-01	J	0°C to +760°C (+32°F to +1400°F)	2, 3, 4	$\pm 0.08\%$ $\pm 0.61^\circ\text{C}$
DSCA47J-02	J	-100°C to +300°C (-148°F to +572°F)	2, 3, 4	$\pm 0.08\%$ $\pm 0.32^\circ\text{C}$
DSCA47J-03	J	0°C to +500°C (+32°F to +932°F)	2, 3, 4	$\pm 0.07\%$ $\pm 0.35^\circ\text{C}$
DSCA47K-04	K	0°C to +1000°C (+32°F to +1832°F)	2, 3, 4	$\pm 0.08\%$ $\pm 0.80^\circ\text{C}$
DSCA47K-05	K	0°C to +500°C (+32°F to +932°F)	2, 3, 4	$\pm 0.08\%$ $\pm 0.40^\circ\text{C}$
DSCA47K-13	K	-100°C to +1350°C (-148°F to +2462°F)	2, 3, 4	$\pm 0.08\%$ $\pm 1.16^\circ\text{C}$
DSCA47K-14	K	0°C to +1200°C (+32°F to +2192°F)	2, 3, 4	$\pm 0.08\%$ $\pm 0.96^\circ\text{C}$
DSCA47T-06	T	-100°C to +400°C (-148°F to +752°F)	2, 3, 4	$\pm 0.16\%$ $\pm 0.80^\circ\text{C}$
DSCA47T-07	T	0°C to +200°C (+32°F to +392°F)	2, 3, 4	$\pm 0.13\%$ $\pm 0.26^\circ\text{C}$
DSCA47E-08	E	0°C to +1000°C (+32°F to +1832°F)	2, 3, 4	$\pm 0.10\%$ $\pm 1.00^\circ\text{C}$
DSCA47R-09	R	+500°C to +1750°C (+932°F to +3182°F)	2, 3, 4	$\pm 0.10\%$ $\pm 1.25^\circ\text{C}$
DSCA47S-10	S	+500°C to +1750°C (+932°F to +3182°F)	2, 3, 4	$\pm 0.10\%$ $\pm 1.25^\circ\text{C}$
DSCA47B-11	B	+500°C to +1800°C (+932°F to +3272°F)	2, 3, 4	$\pm 0.15\%$ $\pm 1.95^\circ\text{C}$
DSCA47N-15	N	-100°C to +1300°C (-148°F to +2372°F)	2, 3, 4	$\pm 0.08\%$ $\pm 1.12^\circ\text{C}$

†Output Ranges Available

Output Range	Part No. Suffix	Example
1. -10V to +10V	NONE	N/A
2. 0V to +10V	NONE	DSCA47J-01
3. 4 to 20mA	C	DSCA47J-01C
4. 0 to 20mA	E	DSCA47J-01E

‡Thermocouple Alloy Combinations

Standards: DIN IEC 584, ANSI MC96-1-82, JIS C 1602-1981

Type	Material
J	Iron vs. Copper-Nickel
K	Nickel-Chromium vs. Nickel-Aluminum
T	Copper vs. Copper-Nickel
E	Nickel-Chromium vs. Copper-Nickel
R	Platinum-13% Rhodium vs. Platinum
S	Platinum-10% Rhodium vs. Platinum
B	Platinum-30% Rhodium vs. Platinum-6% Rhodium
N	Nickel-14.2% Chromium-1.4% Silicon vs. Nickel-4.4% Silicon- 0.1% Magnesium