



Original

User Manual

By On Robot ApS



RG2

Industrial Robot Gripper

Content

1	Preface.....	4
	1.1 Scope of delivery.....	4
	1.2 Important safety notice.....	4
2	Introduction	5
3	Safety instructions	5
	3.1 Validity and responsibility	5
	3.2 Limitations of liability	5
	3.3 Warning symbols in this manual.....	6
	3.4 General warnings and cautions.....	7
	3.5 Intended use	8
	3.6 Risk assessment.....	8
4	Mechanical interface	9
	4.1 Mounting the gripper	9
	4.2 Mechanical dimensions.....	10
	4.3 Load capacity	11
	4.4 Fingers	11
	4.5 Gripper Work Range	12
	4.5.1 Finger thickness	12
	4.5.2 Gripping speed	12
5	Electrical interface	13
	5.1 Tool connections	13
	5.1.1 Power supply	13
6	Technical.....	14
	6.1 Technical Specifications.....	14
7	Gripper programming	15

7.1	Getting started.....	15
7.2	RG2 configuration	15
7.2.1	Mounting setup	15
7.2.1.1	Bracket	15
7.2.1.2	Rotation buttons.....	16
7.2.1.3	TCP radio buttons & values.....	17
7.2.1.4	TCP width	19
7.2.1.5	RG2 dual setup.....	19
7.2.2	Settings.....	20
7.2.2.1	Fingertip offset.....	20
7.2.2.2	TCP settings.....	21
7.2.2.3	Disable single step	21
7.2.2.4	Depth compensation settings	21
7.3	RG2 node.....	22
7.3.1	Width and Force	23
7.3.2	Payload.....	24
7.3.3	Depth compensation.....	25
7.3.4	Feedback and teaching buttons	26
7.3.5	Dual gripper	27
7.4	RG2 TCP node.....	28
7.5	RG2 Script function	29
7.6	RG2 feedback variables	29
7.6.1	Single RG2	29
7.6.2	Dual RG2.....	29
7.7	URCap version.....	30
7.7.1	About screen	30

7.8	UR compatibility	31
8	Declarations and certificates	32
8.1	CE/EU Declaration of Incorporation (original)	32

1 Preface

Congratulations on your new RG2 Industrial Robot Gripper.

The RG2 is an electrical industrial robot gripper that can handle a variation of different object sizes. Typically for pick and place applications. The gripping force as well as the gripping width can be set to custom requirements.

1.1 Scope of delivery



- 1x RG2 Industrial Robot Gripper
- 1x RG2 Mounting Coupling
- 2x RG2 Fingertips
- 1x USB Flash Drive
 - Software
 - Manual
- 1x Bag of bolts
- 3x Allen keys

The appearance of the delivered components may differ from the images and illustrations in this manual.

1.2 Important safety notice

The Gripper is *partly completed machinery* and a risk assessment is required for each application the gripper is a part of. It is important that all safety instructions herein are followed.

2 Introduction

The RG2 is an industrial robot gripper. Designed for grabbing objects, typically used in pick and place applications. Its long stroke allows it to handle a variety of object sizes and the option to adjust the gripping force allows the gripper to handle both delicate and heavy objects. The standard fingers can be used with many different objects, but it is also possible to fit custom fingers. The installation complexity is minimal as the RG2 cable attaches directly onto any supported robot. All configuration of the gripper is controlled in the robot software.

3 Safety instructions

3.1 Validity and responsibility

The information in this manual is not a guide to design a complete robotic application. The safety instructions is limited to the RG2 gripper only and does not cover the safety precautions of a complete application. The complete application must be designed and installed in accordance with the safety requirements specified in the standards and regulations of the country where the application is installed.

The application integrators are responsible for ensuring that the applicable safety laws and regulations in the country concerned are observed and that any significant hazards in the complete application are eliminated.

This includes, but is not limited to:

- Making a risk assessment for the complete application.
- Validating that the complete application is designed and installed correctly.

3.2 Limitations of liability

The safety instructions and other information in this manual is not a guarantee that the user will not suffer injury, even if all instructions are followed.

3.3 Warning symbols in this manual

**DANGER:**

This indicates a serious dangerous situation which, if not avoided, could result in injury or death.

**WARNING:**

This indicates a potentially hazardous electrical situation which, if not avoided, could result in injury or damage to the equipment.

**WARNING:**

This indicates a potentially hazardous situation which, if not avoided, could result in injury or major damage to the equipment.

**CAUTION:**

This indicates a situation which, if not avoided, could result in damage to the equipment.

**NOTE:**

This indicates additional information such as tips or recommendations.

3.4 General warnings and cautions

This section contains general warnings and caution.



WARNING:

1. Make sure that the Gripper is properly mounted.
2. Make sure the gripper is not collided into obstacles.
3. Never use a damaged Gripper.
4. Make sure not to have any limbs in contact with or between the Gripper fingers and finger arms, when it is operating or in teach mode.
5. Make sure to follow the safety instructions of all equipment in the application.
6. Never modify the Gripper. A modification might cause dangerous situations. On Robot DISCLAIMS ANY LIABILITY IF THE PRODUCT IS CHANGED OR MODIFIED IN ANY WAY.
7. When mounting external equipment such as custom fingers make sure that the safety instructions both herein and in the external manual are followed.
8. If the gripper is used in applications where it is not connected to a UR robot. Make sure the connections resembles the analogue input, digital inputs and outputs and the power connections. Make sure you use a RG2 gripper programming script that are adapted to fit your specific application. For more information, please contact your supplier.



CAUTION:

1. When the gripper is combined with or working with machines capable of damaging the gripper, then it is highly recommended to test all functions separately outside the potentially hazardous workspace.
2. When the gripper feedback (I/O ready signal) is relied upon for continuing operation and a malfunction will cause damage to the gripper and/or other machines, it is highly recommended to use external sensors in addition to the gripper feedback for insuring correct operations even if a failure should occur. On Robot cannot be held responsible for any damages caused to the gripper or other equipment due to programming errors or malfunctioning of the gripper.
3. Never let the gripper come in contact with corrosive substances, soldering splashes or abrasive powders as they may damage the gripper. Never let personnel or objects stand within the operating range of the gripper. Never operate the gripper if the machine on which it is fitted does not comply with safety laws and standards of your country.

3.5 Intended use

The Gripper is industrial equipment and intended as an end effector or tool for industrial robots. It is intended for pick and place operations of a variety of different objects.

The RG2 gripper is intended for use with robots from Universal Robots. The information in this manual about electrical connections, programming and use of the gripper are described only for robots from Universal Robots.

**CAUTION:**

Use without a UR robot is not described in this manual and misuse can cause damage to the gripper or the connected equipment.

Collaborative use of the gripper, where humans are close to or within the work area, is only intended for non-hazardous applications, where the complete application, including the object, is without any significant risks according to the risk assessment of the specific application.

Any use or application deviating from the intended use is deemed to be impermissible misuse. This includes, but is not limited to:

1. Use in potentially explosive environments.
2. Use in medical and life critical applications.
3. Use before performing a risk assessment.

3.6 Risk assessment

It is important to make a risk assessment. Since the Gripper itself is considered *partly completed machinery*, it is also important to follow the guidelines in the manuals of all additional machines in the application.

It is recommended that the integrator uses guidelines in ISO 12100 and ISO 10218-2 to conduct the risk assessment.

Below is listed some potential dangerous situations that the integrator as a minimum must take to consideration. Please note that there can be other dangerous situations depending on the specific situation.

1. Entrapment of limbs between the grippers finger arms.
2. Penetration of skin by sharp edges and sharp points on the object.
3. Consequences due to incorrect mounting of the gripper.
4. Objects falling out of the gripper, e.g. due to incorrect gripping force or to high acceleration from a robot.

4 Mechanical interface

The Gripper is constructed in such a way that should a power loss occur, it will maintain the gripping force.

4.1 Mounting the gripper

The design of the standard gripper coupling is in such a way, that the angle of the gripper can be adjusted from 0° to 180° in steps of 30°.

Mount the gripper coupling with 4 pcs M6x8 bolts.
Tighten the bolts with minimum 7Nm.

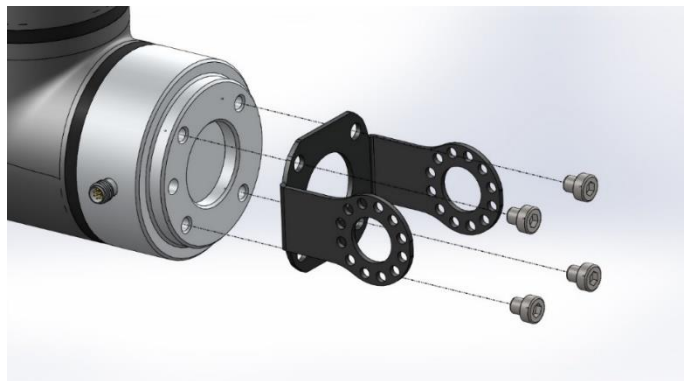

Mount 4-6 pcs M4x8 bolts.
Tighten the bolts with minimum 2Nm.

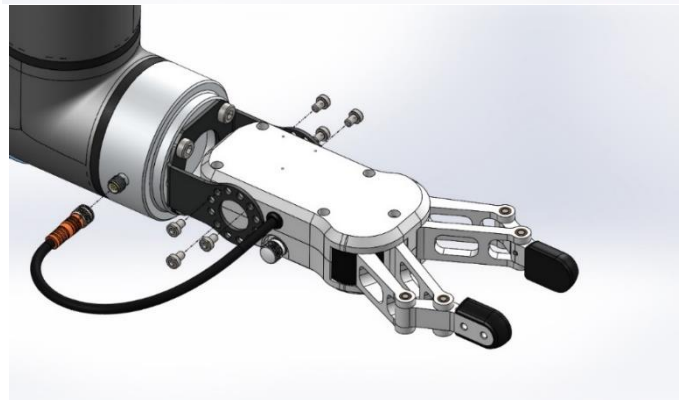
**DANGER:**

Make sure that the gripper is properly mounted using correct torque to tighten the bolts. Incorrect mounting can result in injury.

**CAUTION:**

The M4 threads in the gripper are 6mm deep. Do not exceed this.

4.2 Mechanical dimensions

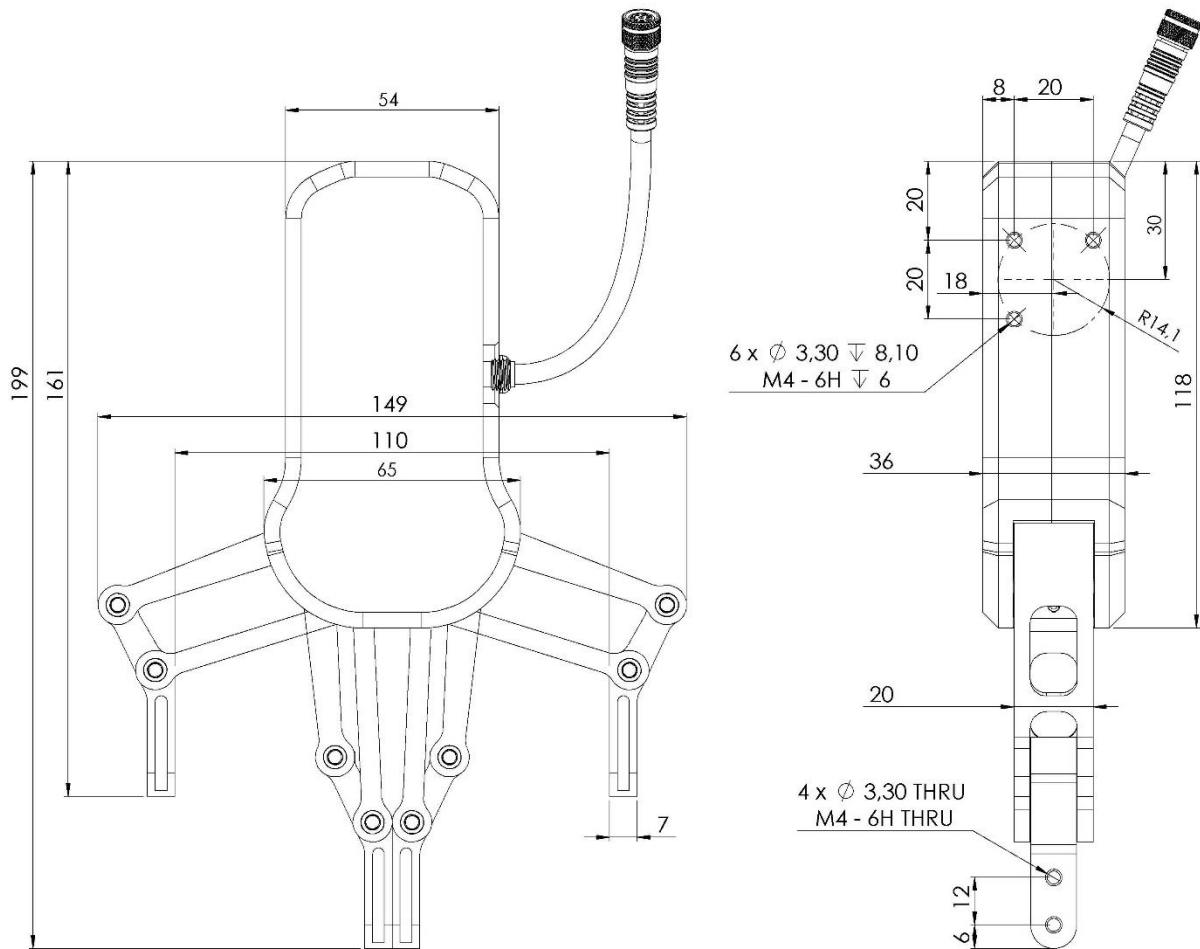

The dimensions are in millimeters (the cable may differ from above drawing)

4.3 Load capacity

Be aware that when grasping an object, some of the parameters below are not directly applicable. But can be used to calculate the load on the gripper.

Parameter	Static	Unit
Fy	362	[N]
Mx	7,55	[Nm]
My	4,1	[Nm]
Mz	6,92	[Nm]
Mx ₁	22	[Nm]
My ₁	11	[Nm]
Mz ₁	22	[Nm]

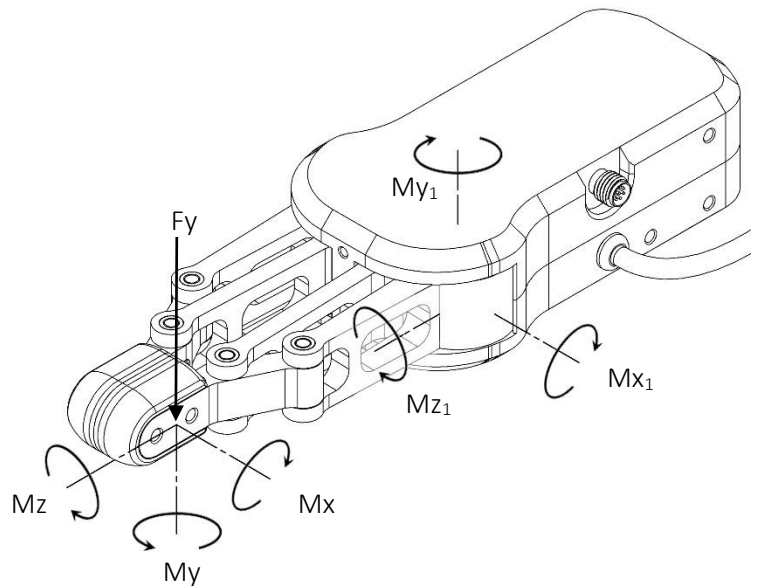

The parameters in the finger tips are calculated at the shown position and will change in relation to the finger positions.

4.4 Fingers

The standard fingers can be used for many different workpieces. If custom fingers are required, they can be made to fit the gripper fingertips.

Standard fingers

For a variety of workpieces

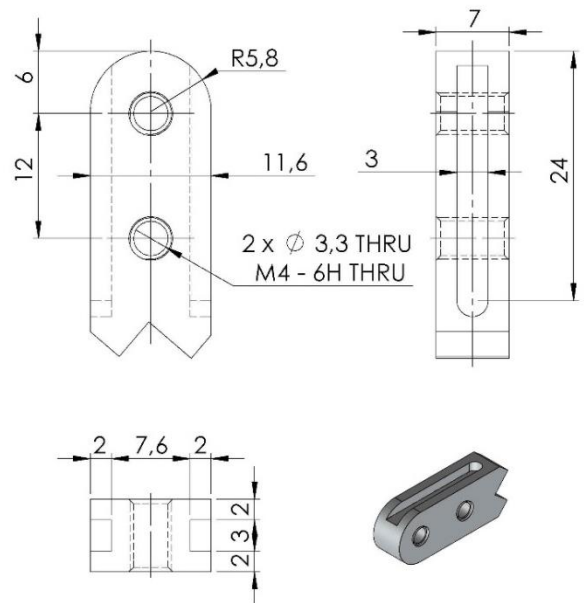

Dimensions of the gripper aluminum fingertips. Dimensions are in millimeters.

4.5 Gripper Work Range

The work range is measured between the aluminum fingers. The gripper can be used for both internal and external grip, e.g. by rotating the fingers. Make sure that the offset is included before entering values into the gripper settings.

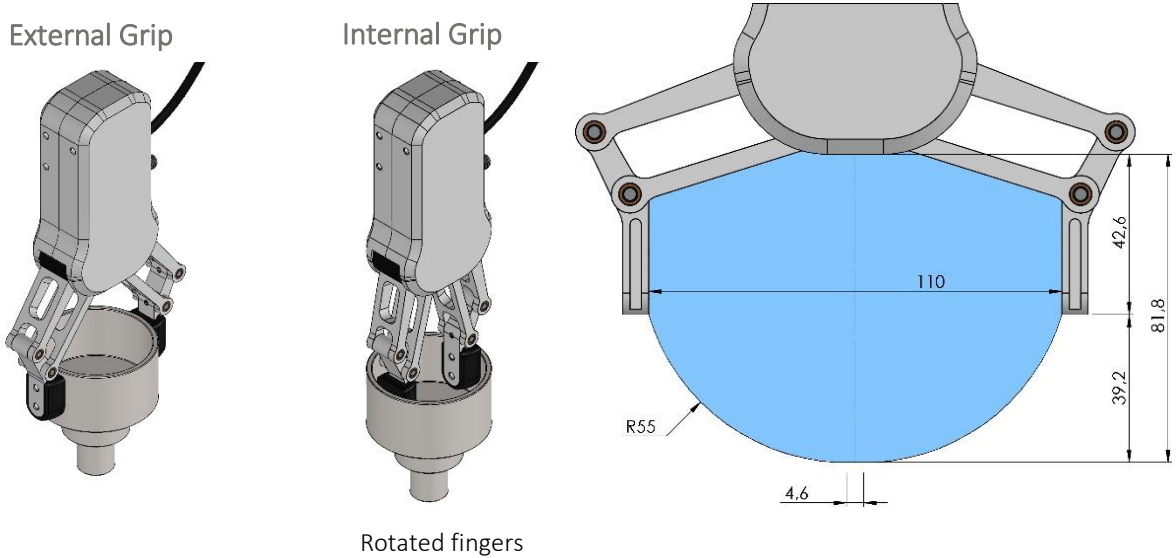

4.5.1 Finger thickness

In this example, we want to grip an object of 20mm. To clear the object before gripping we want to set the gripping width to 28mm in the gripper settings on the robot. Because of the finger thickness, the resulting actual gripper width will be 19mm, which is not enough to clear the object. To calculate the needed setting, you need the finger thickness, which is the offset from the inner aluminum finger to the contact flange of the mounted finger, in this case 4,5mm.

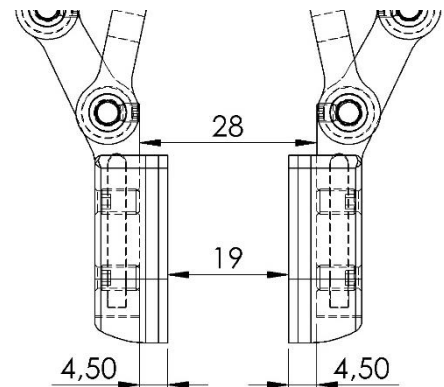

$2 \times \text{finger thickness} + \text{clearing gap} + \text{object width} = \text{Actual gripping width}$

In this example: $2 \times 4,5 + 8 + 20 = 37$ type 37 into the gripper settings on the robot.

4.5.2 Gripping speed

Speed table illustrating the difference in speed relative to the gripper finger position.

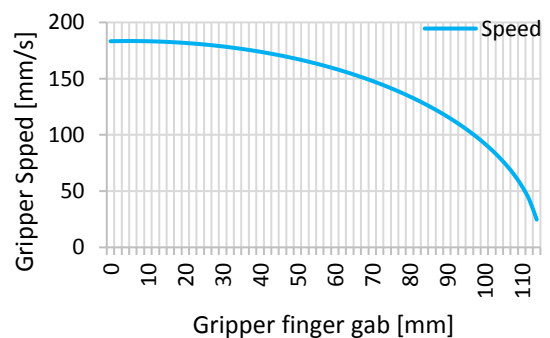

5 Electrical interface

This chapter describes all the electrical interfaces of the gripper. The term “I/O” refers to both digital and analog control signals going from or to the gripper.

5.1 Tool connections

The Gripper cable is intended to fit the tool connector on robots from Universal Robots. The connections are described below. The output tool connector on the gripper shares the same connections as the input cable described below.

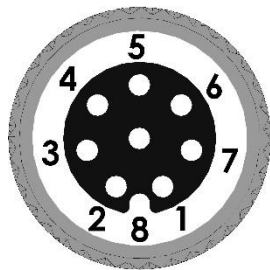

Cable RKMV 8-354

<i>pin</i>	<i>wire</i>	<i>UR tool</i>	<i>UR I/O V3</i>
1	White	AI2	Tool analog input 2
2	Brown	AI3	Tool analog input 3
3	Green	DI9	Tool input 1
4	Yellow	DI8	Tool input 0
5	Gray	Power	24V DC
6	Pink	DO9	Tool output 1
7	Blue	DO8	Tool output 0
8	Red	GND	0V DC



CAUTION:

1. If the gripper is used in applications where it is not connected to a UR robot.
 - i. Make sure the connections resembles the analog input, digital in and outputs and the power connections.
 - ii. Make sure you use a RG2 gripper programming script that are adapted to fit your specific application.
For more information, please contact your supplier.
2. Do not operate the gripper in a wet environment.

5.1.1 Power supply

The gripper can operate at both 12V and 24V. Please Note that at 12V the forces, speed and some of the function tolerances described in this manual does not apply. It is recommended to use 24V.

6 Technical

6.1 Technical Specifications

<i>Technical data</i>	<i>Min</i>	<i>Typical</i>	<i>Max</i>	<i>Units</i>
Total stroke (adjustable)	0	-	110	[mm]
Finger position resolution	-	0,1	-	[mm]
Repetition accuracy	-	0,1	0,2	[mm]
Reversing backlash	0,2	0,4	0,6	[mm]
Gripping force (adjustable)	3	-	40	[N]
Gripping force accuracy	±0,05	±1	±2	[N]
Gripping speed*	55	110	184	[mm/s]
Gripping time**	0,04	0,07	0,11	[s]
Operating voltage***	10	24	26	[V DC]
Power consumption	1,9	-	14,4	[W]
Maximum Current	25	-	600	[mA]
Ambient operating temperature	5	-	50	[°C]
Storage temperature	0	-	60	[°C]
Product weight	-	0,65	-	[kg]

* see speed table

** based on 8mm total movement between fingers, see speed table

***At 12V the gripper runs at approximately half the normal speed

7 Gripper programming

7.1 Getting started

If UR version \geq 3.3 read Quickstart manual for installation and getting started with the URcap plugin. For lower version see 7.8 UR compatibility.

7.2 RG2 configuration

7.2.1 Mounting setup

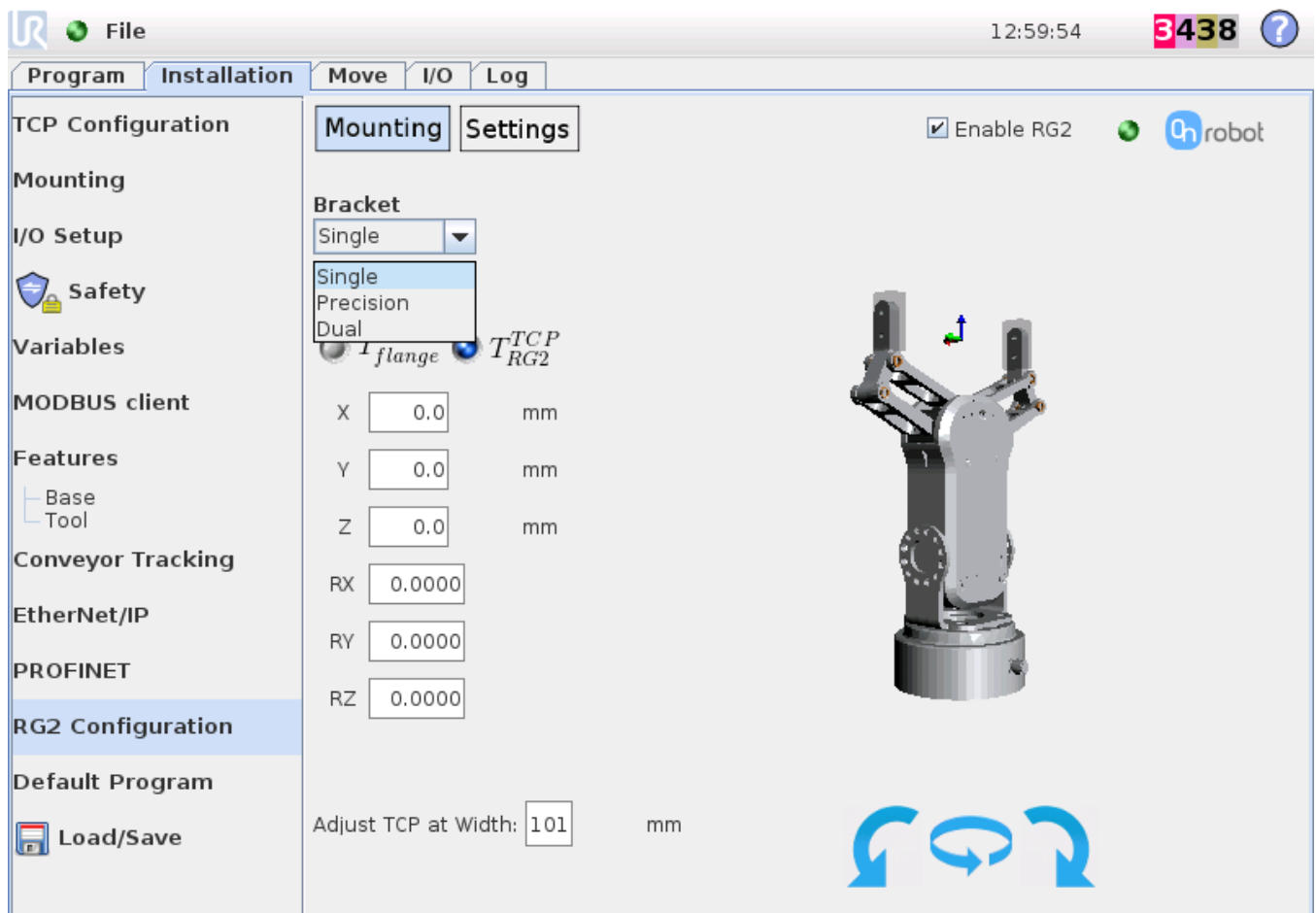

7.2.1.1 Bracket

Select the bracket that is used for mounting the RG2(s) on the robot. The options are “Single”, “Precision” or “Dual”. The “Dual” bracket is used in case of a dual RG2 setup. The “Precision” bracket offers an accurate remount of the RG2 with the rotation options of 90° steps. With the “Single” and “Dual” brackets, the RG2(s) can be rotated at 30° steps.

7.2.1.2 Rotation buttons

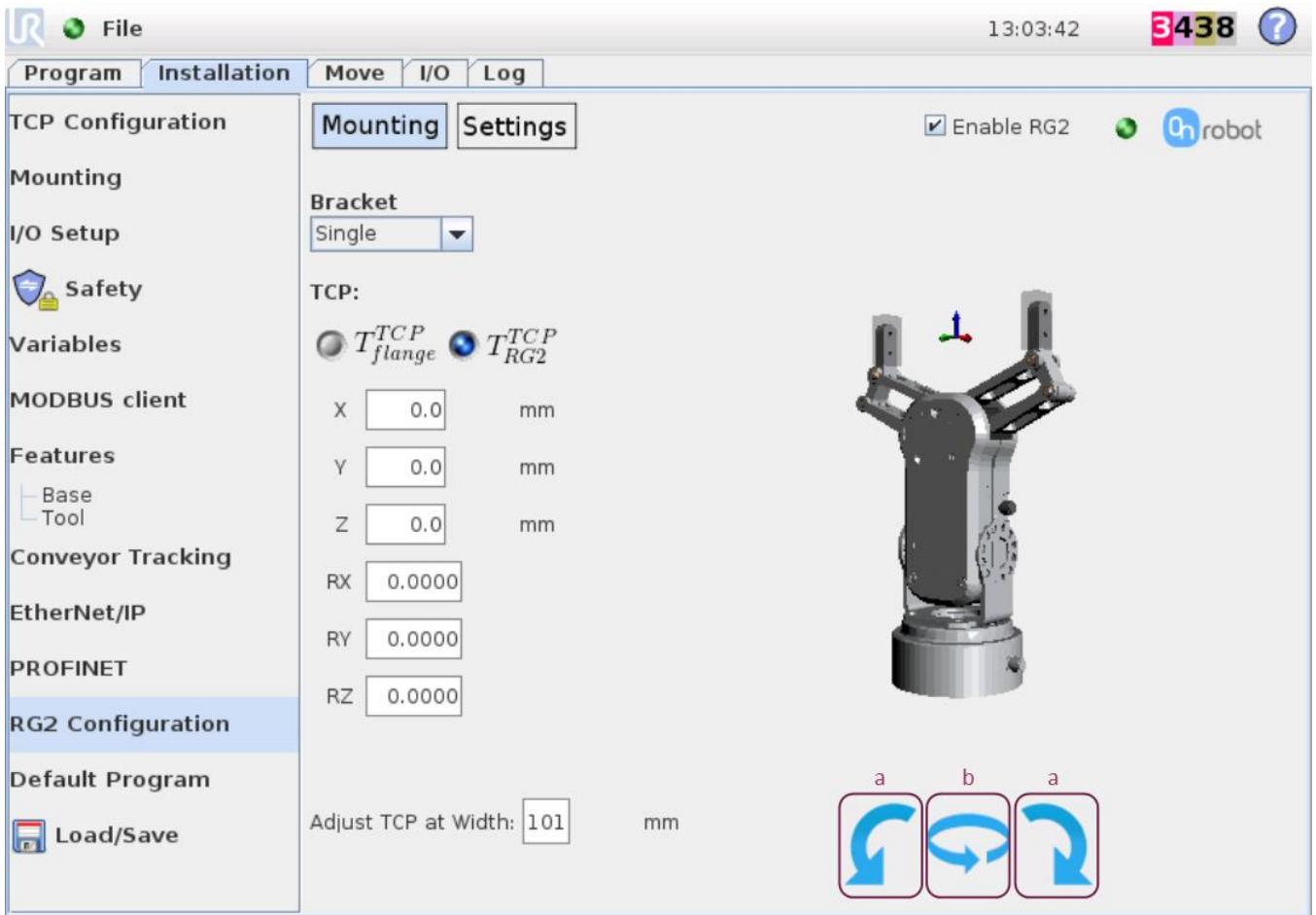

Button marked 'b' will rotate the bracket 90° counter clockwise around the z-axis of the tool flange

Buttons marked 'a' will rotate the selected RG2 +/- the step size (30°/90° depending on bracket).

7.2.1.3 TCP radio buttons & values

The radio button will change if the values represent the transformation from the tool flange to the actual TCP T_{flange}^{TCP} or the transformation for the point in between the fingers of the RG2 to the actual TCP T_{RG2}^{TCP} . The default values of T_{RG2}^{TCP} will always be [0,0,0,0,0,0] while T_{flange}^{TCP} is dependent on bracket and RG2 rotation.

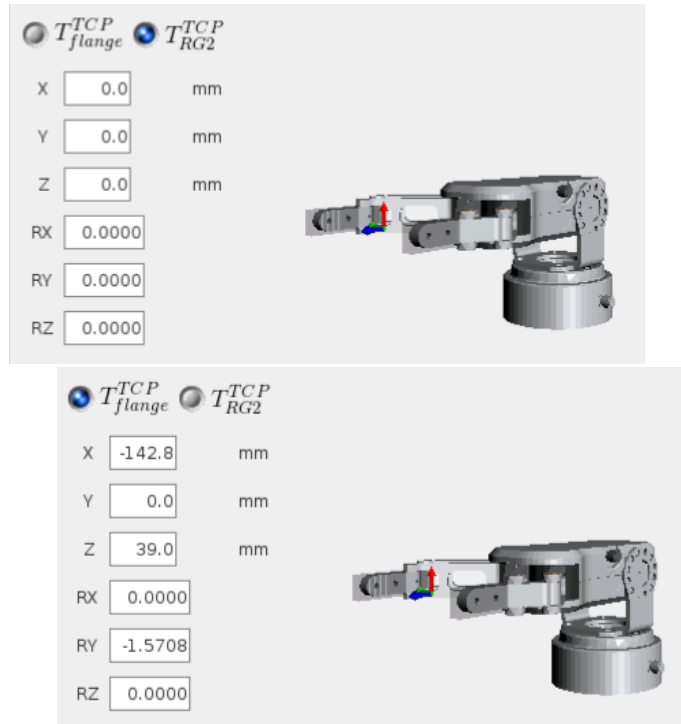

The above example illustrates the difference between how T_{RG2}^{TCP} and T_{flange}^{TCP} is calculated.

The fields [X,Y,Z,RX,RY,RZ] serve both as input and output. When T_{flange}^{TCP} is selected, the values will be affected by pressing the Rotation buttons and entering a new TCP width. The values of [X,Y,Z,RX,RY,RZ] can always be overwritten. If a reset is wanted the TCP radio button should be set to T_{RG2}^{TCP} and [0,0,0,0,0,0] should be filled in in the rotation vectors [X,Y,Z,RX,RY,RZ].

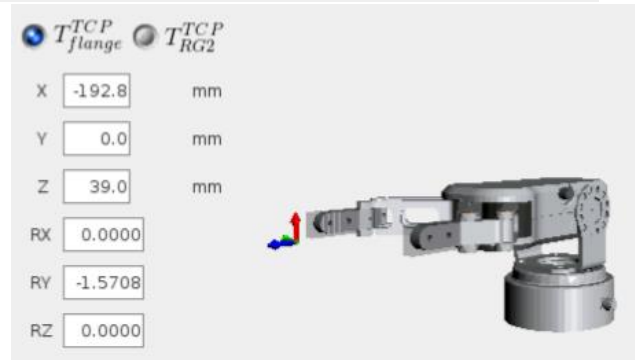
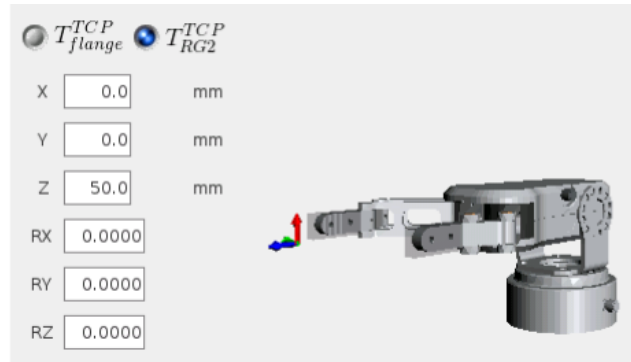

The example shown above is to illustrate what to take into account, if you extend the RG2 fingers by 50 mm.

7.2.1.4 TCP width

Is defining the reference width for the point in between the fingers. A low value will increase the displacement from the bracket to the point in between the fingers, while a higher width will decrease the displacement.

7.2.1.5 RG2 dual setup

If the dual bracket is selected, the radio buttons “Master” and “Slave” will appear and are used to control the rotation of the two RG2 grippers. The Master/Slave radio buttons will select if it is the Master or the Slave RG2 that should perform the action.

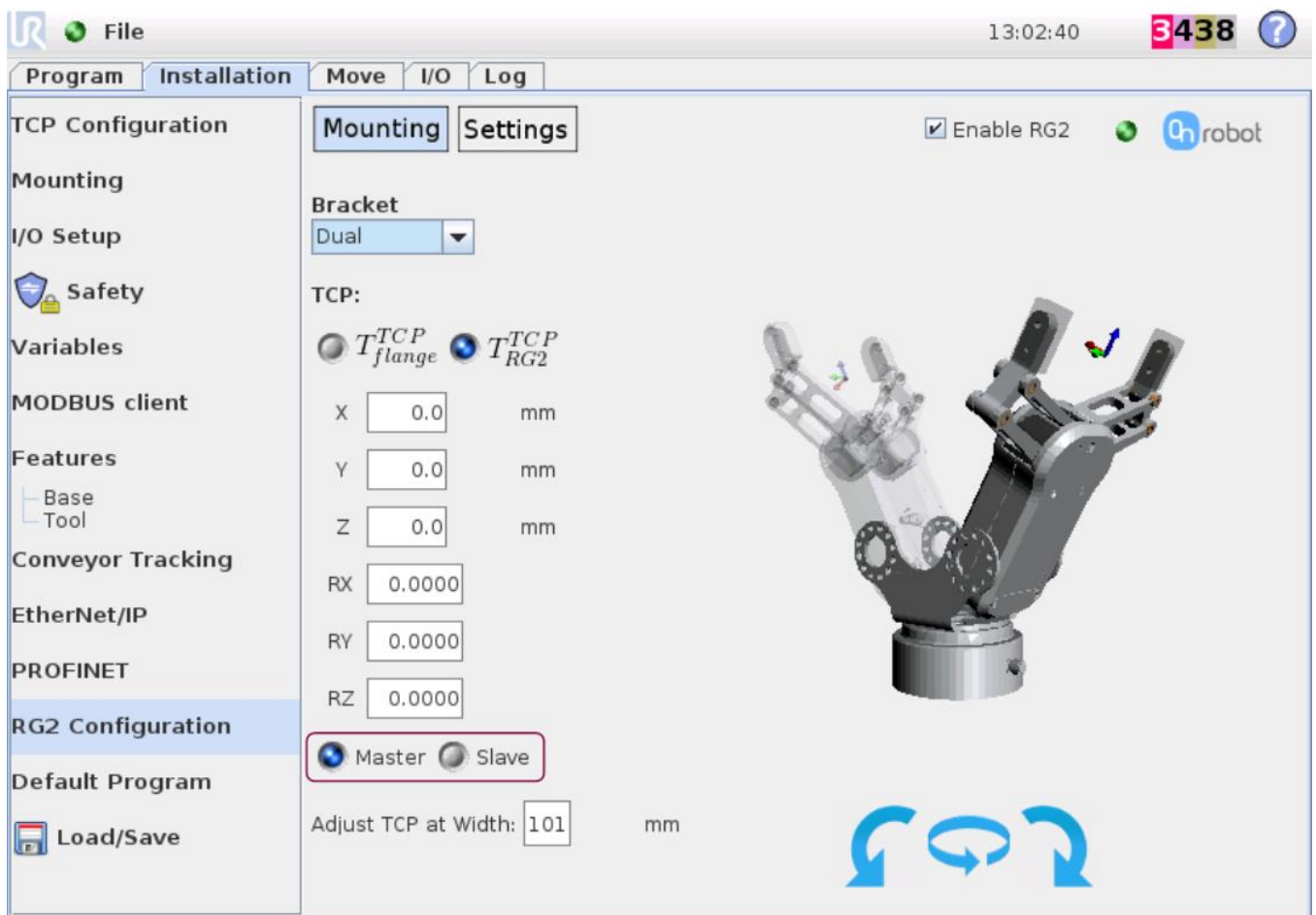

7.2.2 Settings

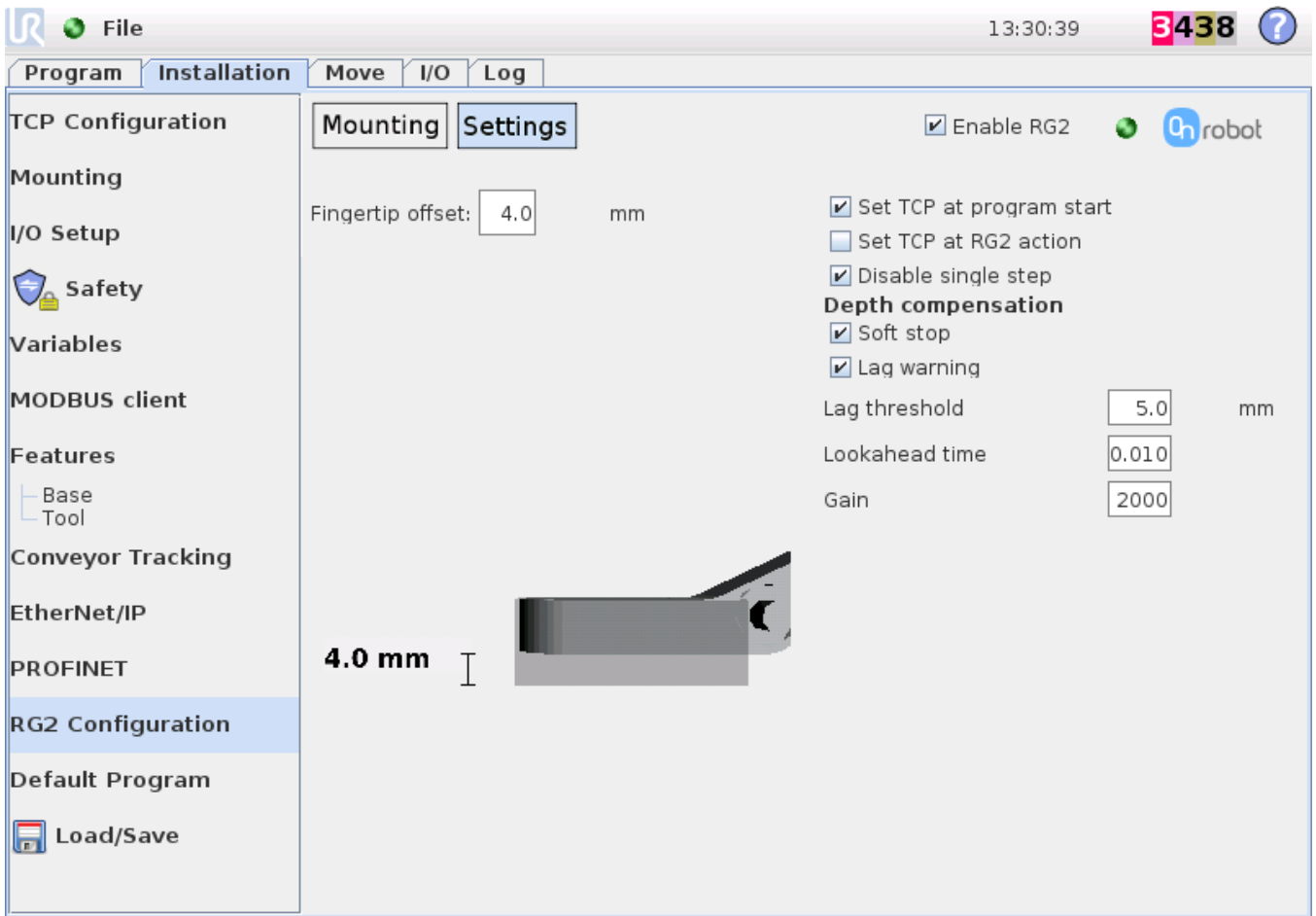

7.2.2.1 Fingertip offset

The fingertip offset is used to specify the distance from the inside of the RG2 aluminum fingertip to the reference point on the attached fingertip.

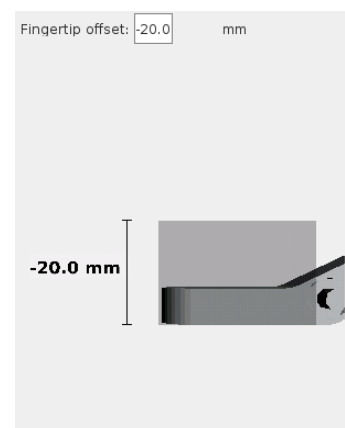
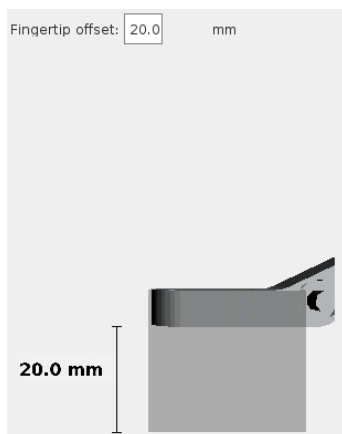

The above examples show how the URCap uses the typed in offset.

7.2.2.2 TCP settings

The option to make the URCap plugin set the TCP [X,Y,Z,RX,RY,RZ] rotation vectors at program start and/or every time the RG2 performs an action, is available at the top right corner.

If the TCP is controlled manually and the “depth compensation” is not used it is recommend to disable both check marks. If the TCP is changed dynamically (during a program) and the “depth compensation” is used, it is recommended to enable “set TCP at RG2 action”.

7.2.2.3 Disable single step

If “Disable single step” is selected, the robot program can be started fast and is not dependent on the number of RG2 nodes, but in this case it is not possible to single step the RG2 nodes. If it is deselected, the case is the opposite. This option is also located in the top right corner.

7.2.2.4 Depth compensation settings

All the “Depth compensation” settings are used for controlling how the Depth compensation should behave, when a RG2 node is set to enable Depth compensation.

“Soft stop” will reduce all robot joint accelerations at the end of the compensation and minimize the integrated compensation error, but will make a small increase of the node execution time.

If the “Lag warning” is enabled the robot will give a warning if the robot movement lags the RG2 above the specified threshold. The reason for lag can be a low value of the speed slider, low gain, high lookahead time, strict safety settings, robot kinematic, fast RG2 movements (high force) and full RG2 stroke.

The “Lag threshold” is the threshold that will trigger a warning message if the lag warning is enabled.

The “Gain” is the gain used for the **servoj** function used in the depth compensation. See the UR script manual.

The “Lookahead time” is the lookahead time used for the **servoj** function used in the depth compensation. See the UR script manual.

7.3 RG2 node

To add a RG2 node, go to the **Program** tab select **Structure** and then the **URCaps** tab. Press the **RG2** button to add the node.

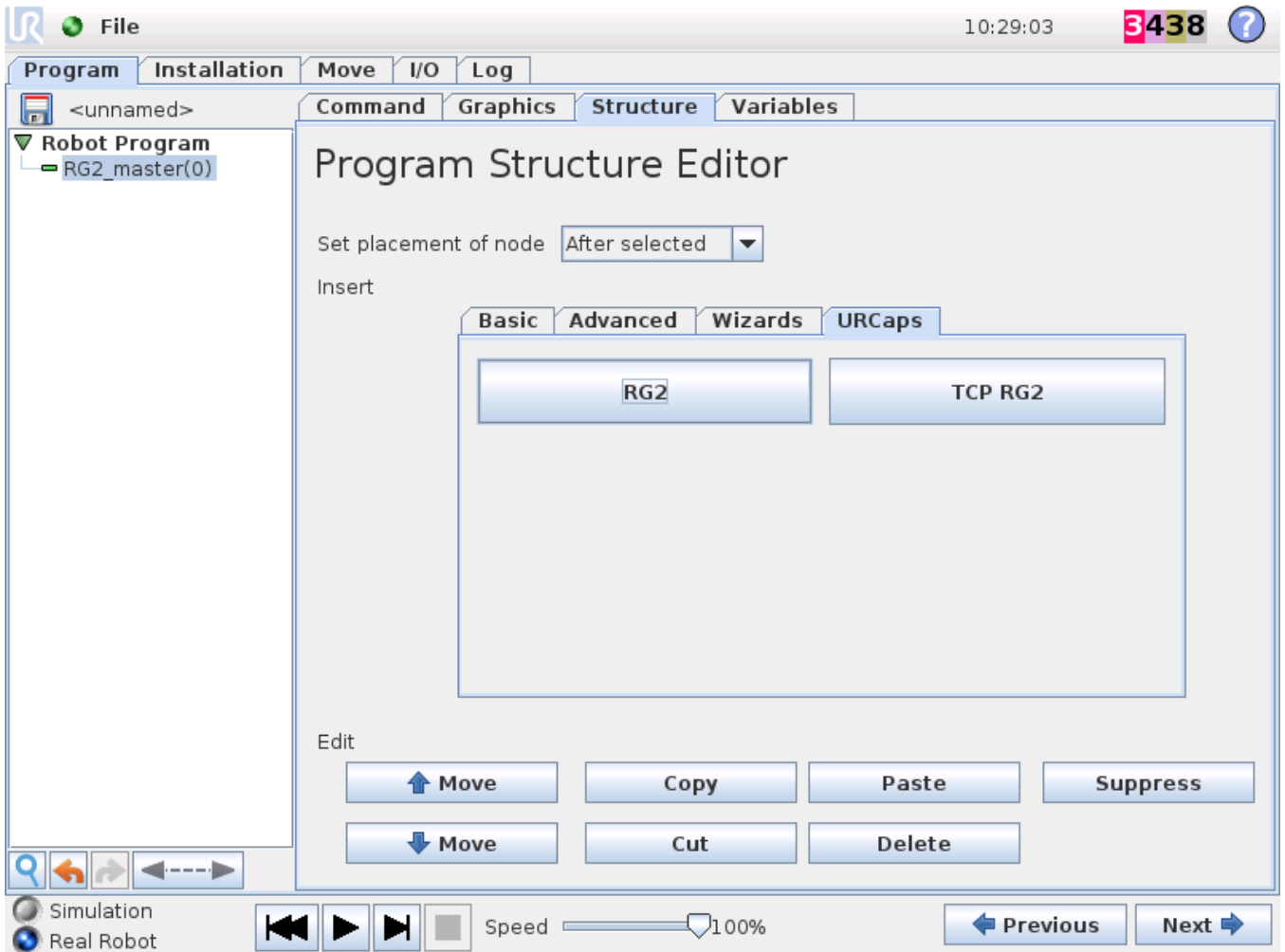

7.3.1 Width and Force

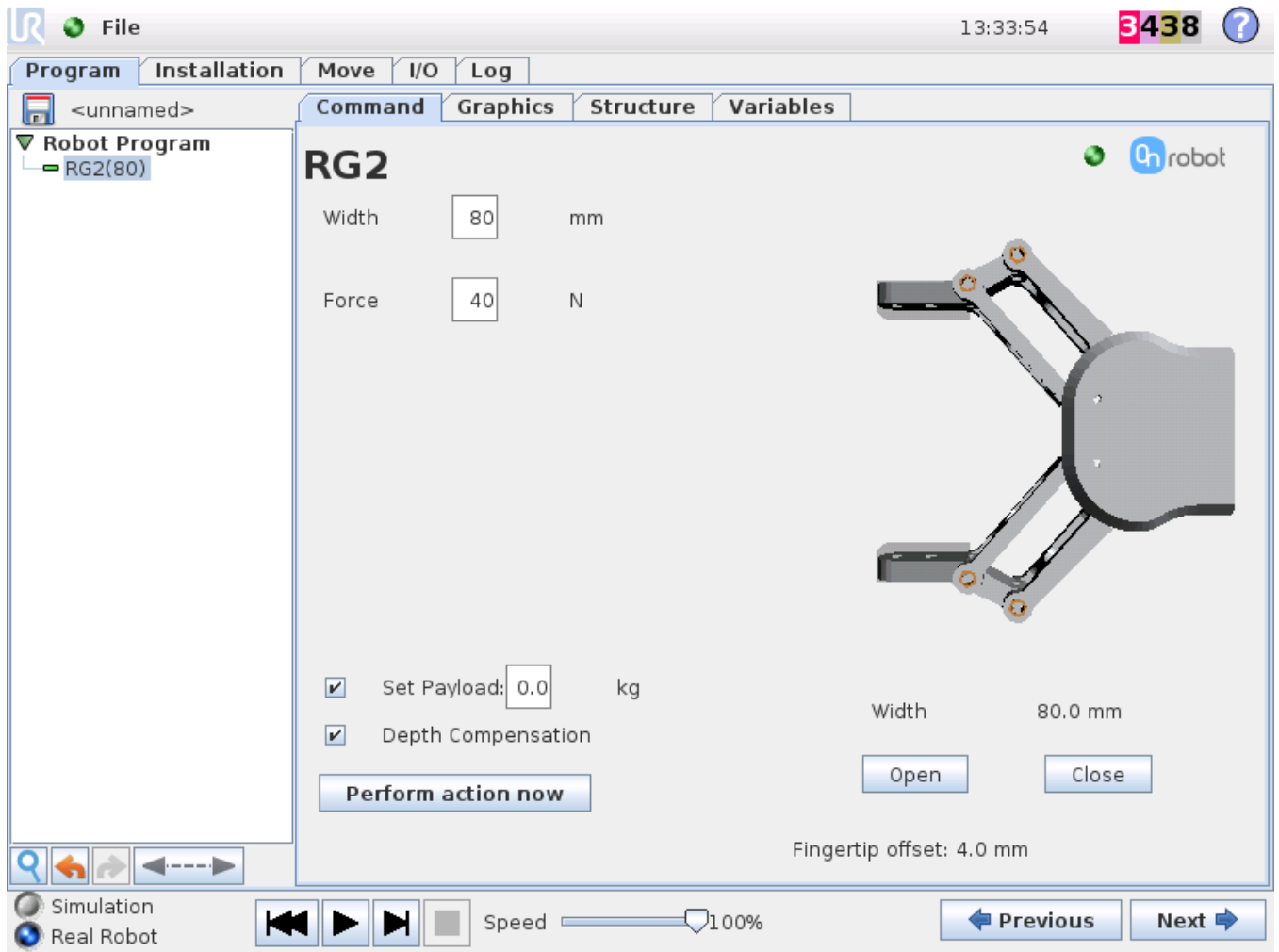

“Width” is the target width that the RG2 will try to reach. If the specified force is achieved, the RG2 will stop at a width that differs from the target width.

“Force” is the target force that the RG2 will try to achieve. If the target width is reached before the target force, the RG2 will stop moving and the target force may not be achieved at the anticipated width.

7.3.2 Payload

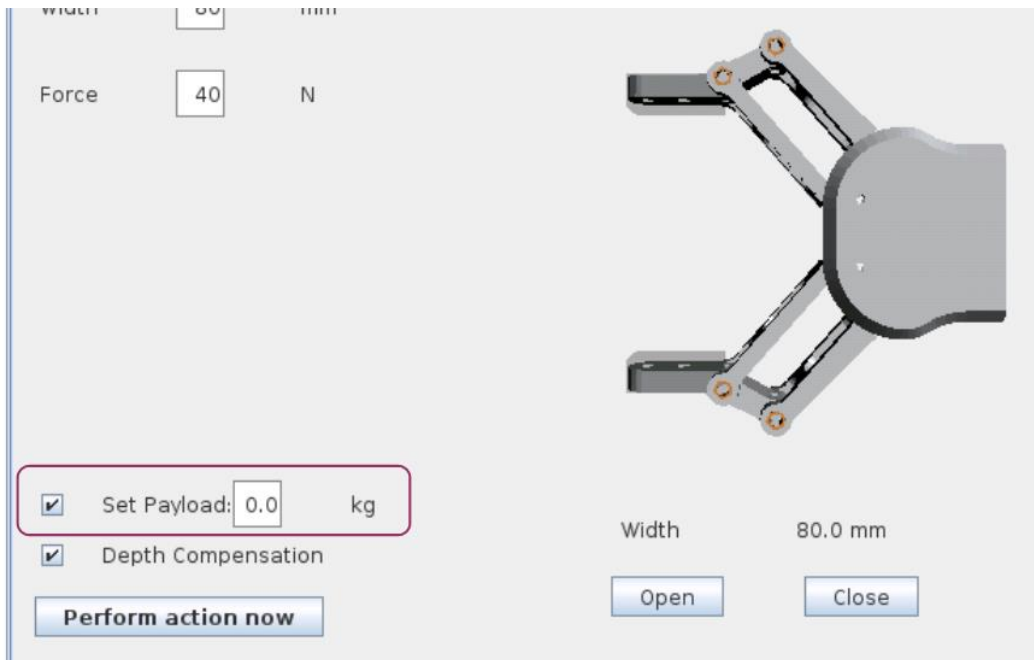

When the “Set Payload” calculation is selected, the object weight must be entered in the Payload field. The URcap plugin will then perform the calculation of the resulting payload mass (sum of bracket, RG2(s) and object). The center of mass for the object is assumed to be in the TCP. The object for the active gripper is only taken into the calculations if an object is grasped.

The math behind the calculations:

$$M = \sum_{i=1}^n m_i$$

$$\mathbf{R} = \frac{1}{M} \sum_{i=1}^n m_i \mathbf{r}_i$$

n: number of present components

i: bracket, RG2_master, RG2_slave, master_object, slave_object

m: mass for each component

r: center of mass vector for each component

M: resulting mass send to UR controller (payload)

R: resulting center of mass vector (CX=Rx, CY=Ry, CZ=Rz)

The above formulas correlates with the TCP configuration setup, which is shown below for reference. To make it simple, when the “Set Payload” is selected, it is only necessary to take the weight of the object handled into account.

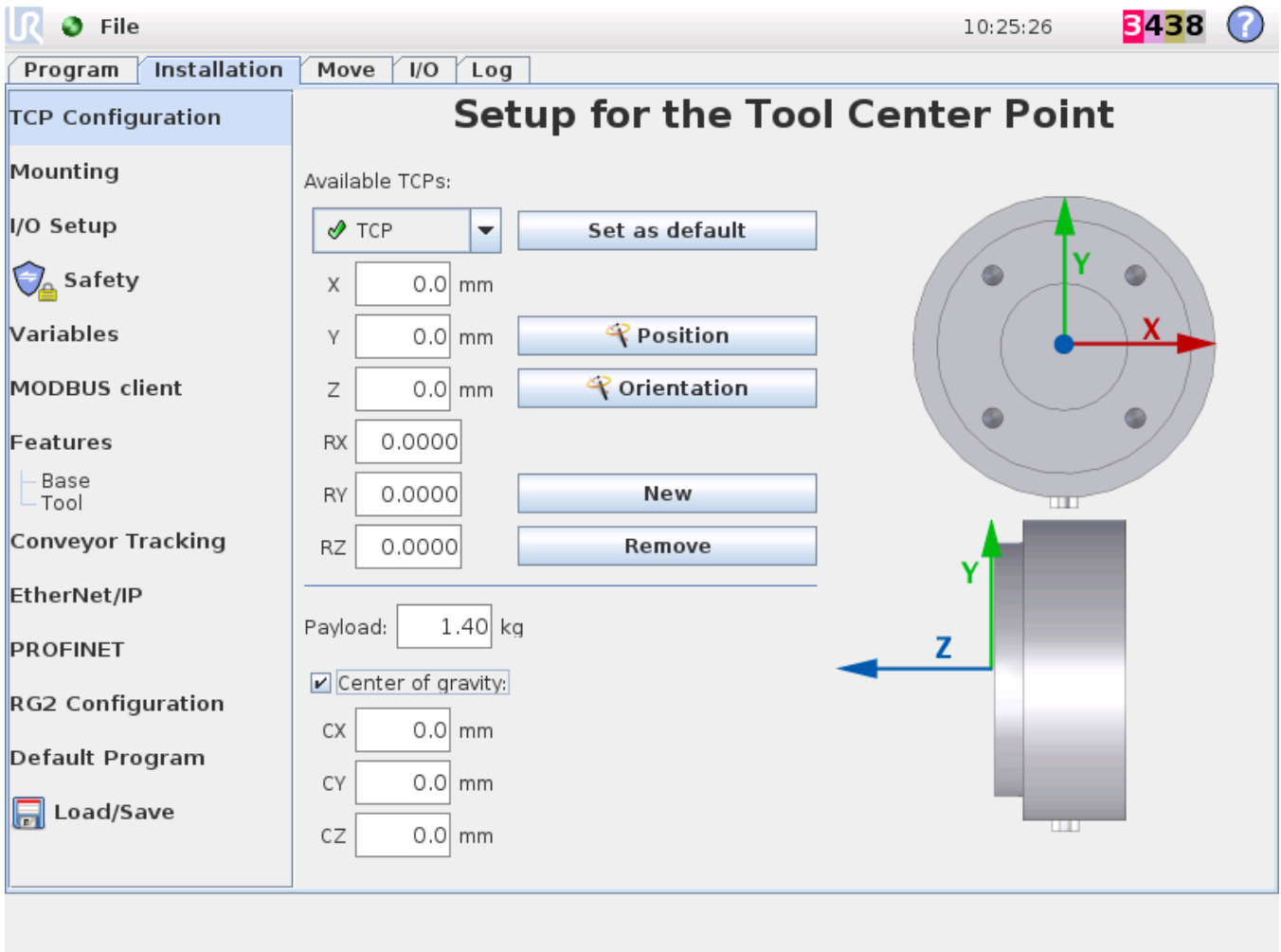

Two examples of what the URCap will calculate in the case the RG2 will pick a workpiece with the mass of 0.5Kg

Single mount bracket:

Robot payload = 0.09kg(bracket) + 0.65kg(RG2) + 0.5kg(work piece) = 1.24kg

Dual mount bracket:

Robot payload = 0.18kg(dual bracket) + 0.65kg(RG2 master) + 0.65kg(RG2 slave) + 0.5kg(work piece) = 1.98Kg

7.3.3 Depth compensation

When the depth compensation is enabled, the robot arm will try to make a movement that compensates for the circular movement of the finger arms. There will be a small lag between the RG2 and robot arm movement. This lag will be dependent on the settings set in the installation, see 7.2.2.4. The compensation is done along the z-axis, so any manual change that will change the orientation of the z-axis will affect the compensation.

7.3.4 Feedback and teaching buttons

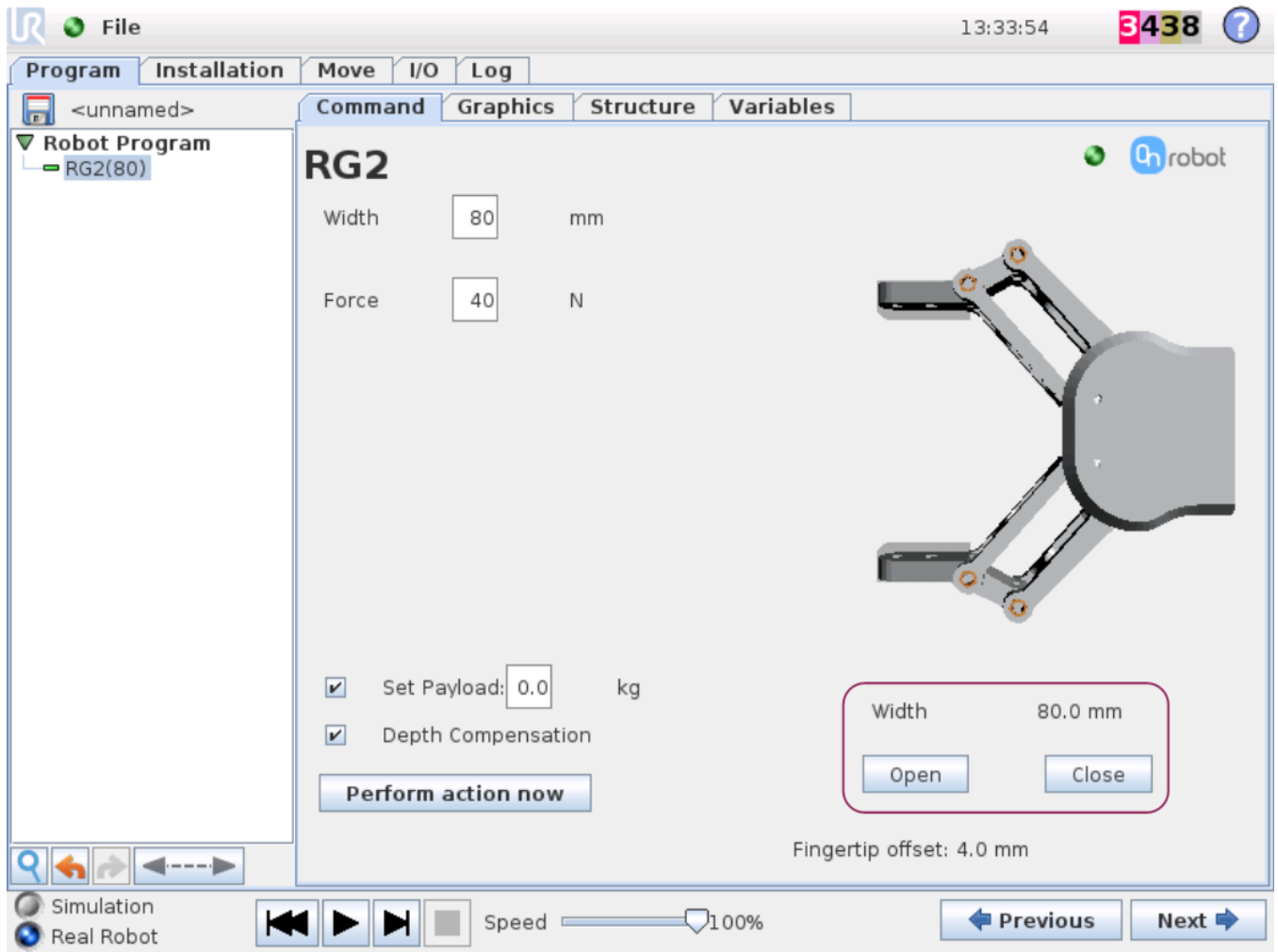

The open and close buttons is “hold to run” buttons that will open and close the (selected) RG2. The above shown illustration and the width text will give feedback about the actual width and if a work piece is grasped.

7.3.5 Dual gripper

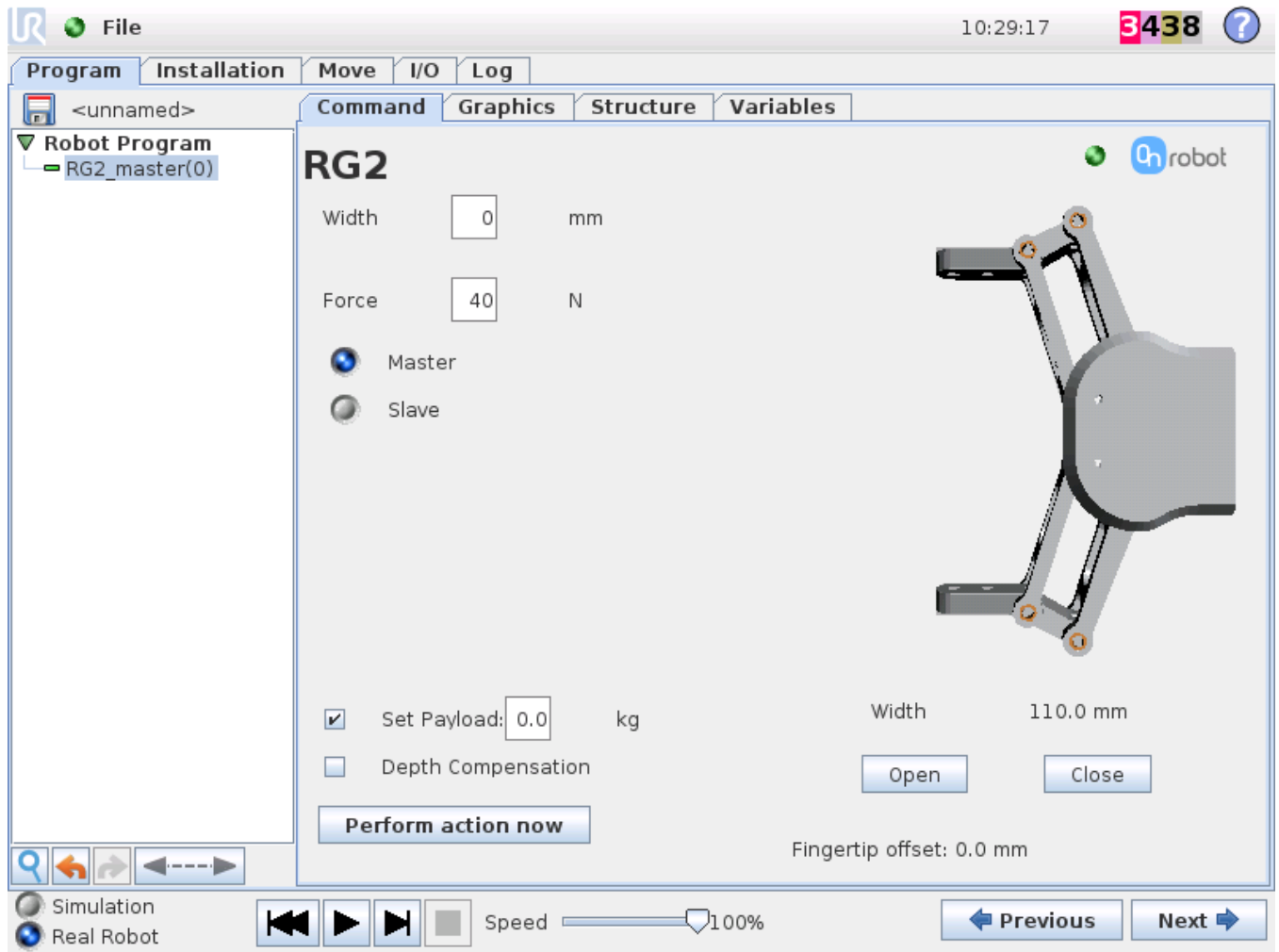

Master/Slave select if it is the master or slave that should perform the action.

7.4 RG2 TCP node

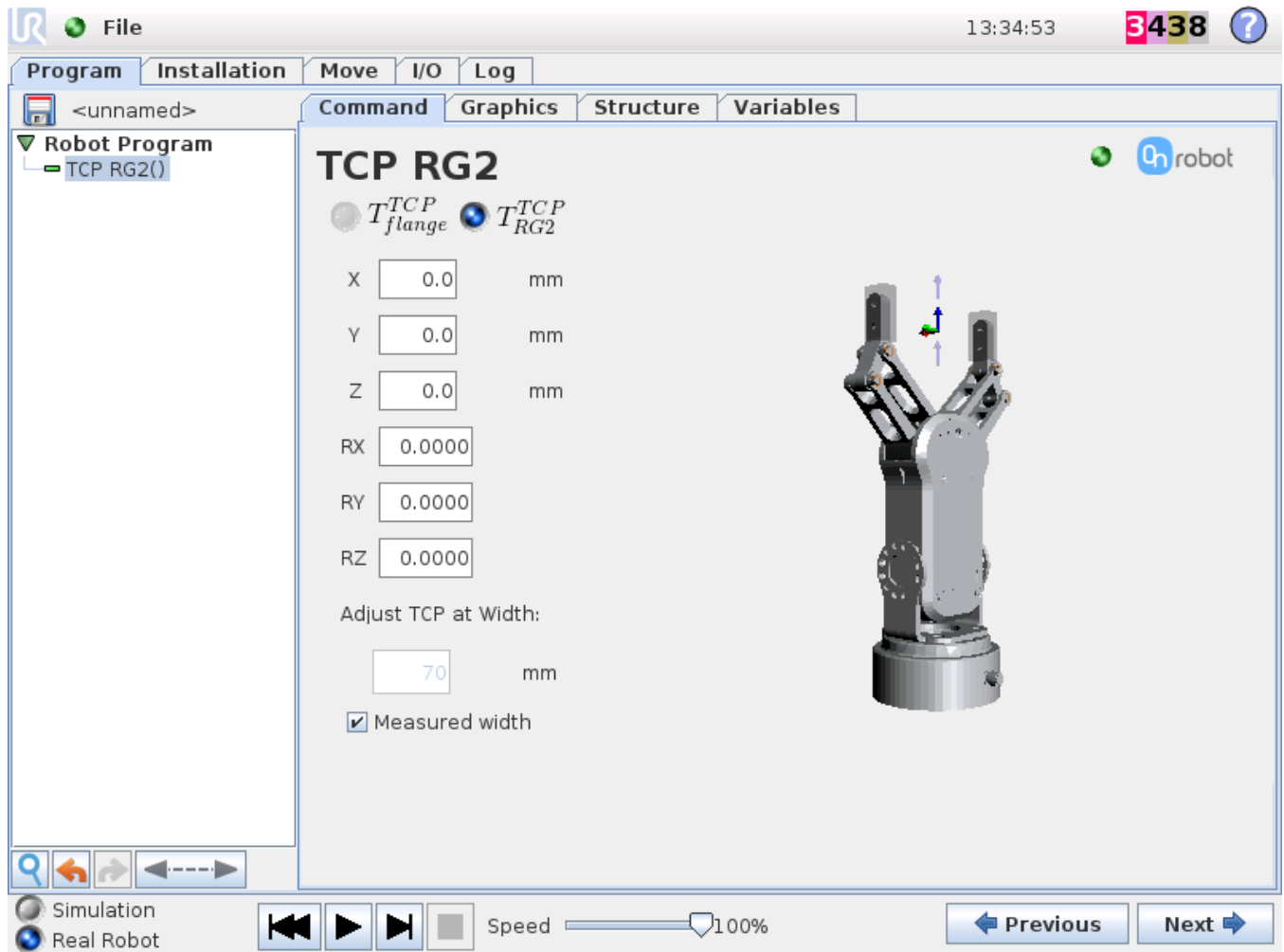

The RG2 TCP node can be inserted to set the current TCP for the robot. The view and the controls are similar to the Mounting setup screen. The “TCP radio buttons & values” and “TCP width” is identical to the settings from the Installation, except that they only affect the single node and not the installation. For explanation, please see 7.2.1.3 and 0 (if dual grippers are installed see 7.2.1.5 and 7.3.5).

7.5 RG2 Script function

When the On Robot URCap is enabled, there will be a defined RG2 script function:

RG2(target_width=110, target_force=40, payload=0.0, set_payload=False, depth_compensation=False, slave=False)

All the input arguments are the same as the one used by the RG2 node. The script function is useful for parameterized programming. For example a relative movement for quick releasing a work piece can be done like this:

RG2(measure_width+5, 40)

That will open the gripper 5mm with the target force set to 40N.

And if a soft/compliant work piece needs to be marked with a certain depth(2mm) it could be done with:

RG2(target_width=0, target_force=3, depth_compensation=True)

RG2(target_width=measure_width-2, target_force=40, depth_compensation=True)

7.6 RG2 feedback variables

7.6.1 Single RG2

<i>Feedback variable</i>	<i>Unit</i>	<i>Description</i>
grip_detected	True/False	True if gripper has detected a work piece
lost_grip	True/False	True if gripper has dropped a work piece
measure_width	[mm]	Width between the fingers of the gripper

7.6.2 Dual RG2

<i>Feedback variable</i>	<i>Unit</i>	<i>Description</i>
master_grip_detected	True/False	True if master has detected a work piece
master_lost_grip	True/False	True if master has dropped a work piece
master_measure_width	[mm]	Width between the fingers of the master
slave_grip_detected	True/False	True if slave has detected a work piece
slave_lost_grip	True/False	True if slave has dropped a work piece
slave_measure_width	[mm]	Width between the fingers of the slave

7.7 URCap version

7.7.1 About screen

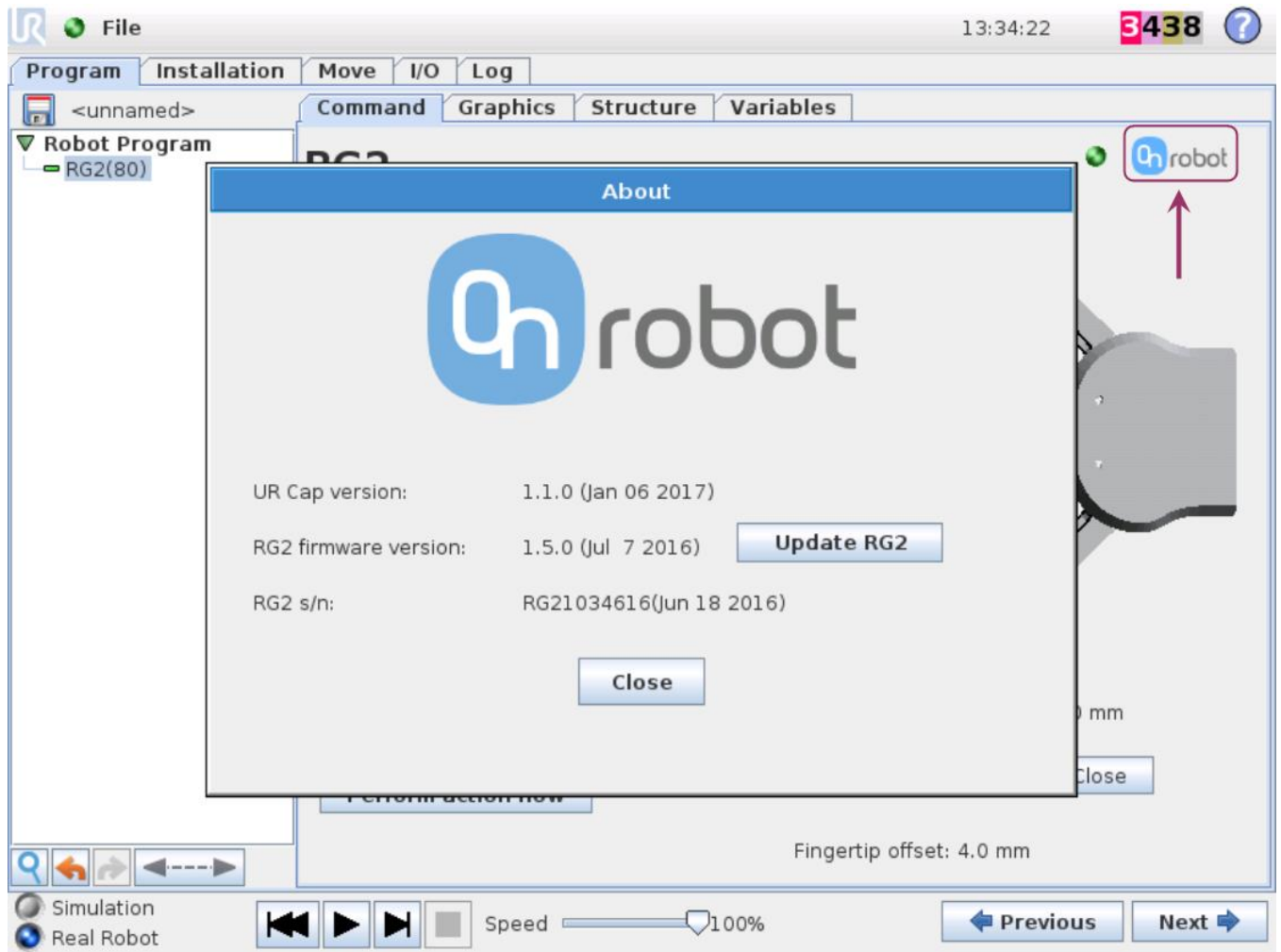

When pressing the Onrobot logo in the top right corner, the above box will appear. From this box it is possible to update the RG2 firmware and to see which version of the URCap is installed.

7.8 UR compatibility

If the UR version is $3.0 \leq$ and ≥ 3.3 . It is recommended to upgrade the robot to the newest available UR software and install the URCap plugin that is installed in this manual. If the robot is < 3.0 the On Robot USB pen will detect it and install the templates needed for your robot version. In such case please see the User Manual version 1.44 placed on the USB in the folder “\ON\CLASSIC\Technical support”.

Compatibility overview:

RG2 Robot program	RG2 firmware < 1.5	RG2 firmware ≥ 1.5	Robot SW < 1.6	Robot SW < 3.3	Robot SW ≥ 3.3
Retro URP files	✓	✓	✓	✓	✓
Classic URP files	✓	✓	✗	✓	✓
Cap plugin	✓	✓	✗	✓	✓

- ✓ Fully compatible
- ✓ Upgrade needs to be done
- ✗ Not compatible

If the firmware version is too low, the URCap will automatically guide you to update the firmware.

8 Declarations and certificates

8.1 CE/EU Declaration of Incorporation (original)

According to European Machinery Directive 2006/42/EC annex II 1.B.

The manufacturer:

On Robot ApS
Havnegade 100 A
5000 Odense C
Denmark
+45 4094 3348

declares that this product:

Type: Industrial Robot Gripper
Model: RG2
Serial number: RG2-10260-16 to RG2-19999-17

is partly completed machinery according to 2006/42/EC. The product must not be put into service before the complete machine is in full compliance with all essential requirements of 2006/42/EC. A comprehensive risk assessment must be carried out for each application as part of ensuring that all essential requirements are fulfilled. All essential requirements must be assessed. Instructions and guidance provided in the RG2 user manual must be followed.

Technical documentation compiled according to 2006/42/EC annex VII part B is available to national authorities upon request.

The product is in conformity with, and CE marked according to, the following directives:

2014/30/EU — Electromagnetic Compatibility Directive (EMC)
2011/65/EU — Restriction of the use of certain hazardous substances (RoHS)



Bilge Jacob Christiansen
CEO & founder
Odense, April 20th, 2016